

MANNINGHAM

DEVELOPMENT GUIDE

for areas of
Environmental
and
Landscape
Significance
2011



CONTENTS

| | |
|---|-----------|
| 1. PURPOSE OF THE GUIDE | 3 |
| Background | 3 |
| Where Does This Guide Apply? | 3 |
| What Does The Guide Do? | 3 |
| How To Use This Guide | 3 |
| 2. INTEGRATED SITING AND DESIGN | 4 |
| 3. VEGETATION | 8 |
| 4. EARTHWORKS | 13 |
| 5. BUILT FORM AND SUSTAINABLE DEVELOPMENT | 17 |
| 6. INTEGRATED WATER MANAGEMENT | 22 |
| 7. BUSHFIRE SAFETY – PLANNING AND BUILDING INFORMATION | 30 |
| 8. APPLICATION REQUIREMENTS | 33 |
| 8.1 Site Analysis Plan | 33 |
| 8.2 Landscape Plan | 34 |
| 8.3 Site Plan | 35 |
| 8.4 Net Gain Assessment | 35 |
| 8.5 Arborist's Report | 36 |
| 8.6 Land Management Plan | 36 |
| 9. FURTHER INFORMATION, RESOURCES AND CONTACTS | 39 |

1. PURPOSE OF THE GUIDE

BACKGROUND

The semi-rural qualities, scenic landscapes with tree cover and remnant bushland in many parts of Manningham, provide a setting and a lifestyle quality that is very attractive to many existing and potential property owners. Manningham's 'liveability' is due to its high environmental values and attractive and significant natural and semi-rural landscapes.

Manningham City Council aims to conserve and manage these areas of environmental and landscape significance so that the total quality of life we enjoy now and in the future can be maintained. This means making sure developments are responsive to the environment and the landscape. In this way, Council aims to ensure *sustainable* development. Sustainable development and land-use in Council's view refers to:

'Using, conserving and enhancing the community's resources so that ecological processes on which life depends are maintained, and the total quality of life now and in the future can be increased.'

WHERE DOES THIS GUIDE APPLY?

The guide is referenced in a number of the Environmental Significance Overlays and Significant Landscape Overlays and is applicable to all properties affected by these overlays. Property owners can contact Statutory Planning on 9840 9495 for information regarding planning controls.

Property owners in areas not affected by these overlays may also find the Guide to be a useful tool in planning to develop their site in a sustainable manner.

WHAT DOES THE GUIDE DO?

This guide aims to provide existing and potential property owners with a clear understanding of what Council expects and what information is required for planning permit applications in Manningham's areas of environmental and landscape significance.

It provides information on how property owners can develop and use properties in a sustainable way. The guide can also assist property owners to get to know their property, and in so doing, locate their

home and other development features in response to the characteristics of the site. This type of approach, practised collectively by property owners, will help to maintain the desirable characteristics of the area. It will also help in designing their home to be a more sustainable, comfortable and healthy place to live.

In particular, this guide requires and encourages:

- Co-ordinated site planning for all development features to achieve an integrated outcome for a site
- Avoiding and minimising the removal of, or adverse impacts upon, native vegetation
- An approach to development with techniques to minimise the need for and extent of earthworks to preserve and enhance natural drainage lines and waterways
- Building forms that respect and are responsive to the landscape
- Environmentally sustainable designs and developments.

HOW TO USE THIS GUIDE

The **Objectives** in this guide describe the outcomes to be achieved in a development application. The associated **Standards** describe the requirements or measures your application needs to satisfy, to achieve the objectives. A standard should normally be met i.e. it is a requirement. However, if Council as the responsible authority is satisfied that your application has an alternative design solution that meets the objective, the alternative design solution may be considered.

The **Hints and Tips** provide advice about how to meet the objectives and standards to assist in the timely processing of your planning permit application.

PLEASE NOTE

The failure to follow or adequately respond to the issues in this guide may result in delays, obstacles and added costs in the timely processing of your planning permit application. In the worst case it may result in your planning permit application not being approved. It is therefore in your best interests to read this guide carefully and ensure your application responds to the issues appropriately.

2. INTEGRATED SITING AND DESIGN

OVERVIEW

Careful consideration and co-ordination of all aspects of a development is important.

Development must appropriately respond to and address site opportunities and constraints. Development features should be sited to achieve an 'integrated design' that realises a site's potential while respecting, enhancing and maintaining the environmental qualities of the surrounding landscape.

Detailed consideration of the remnant bushland and other significant vegetation on a site will help to ensure the new development has a positive relationship with the natural environment. This consideration early in the design process, in the form of 'site analysis', will allow both the natural and built environments to integrate without negatively impacting on each other. Development needs to minimise the visual impact on surrounding properties and views from the road and public open space.

INTEGRATED SITING AND DESIGN

OBJECTIVES

1. To ensure that developments are designed and sited to respond to the topography, soils, waterways, vegetation, view lines and any other notable features of the site.
2. To ensure that development is sited and designed to avoid and minimise vegetation removal and earthworks.

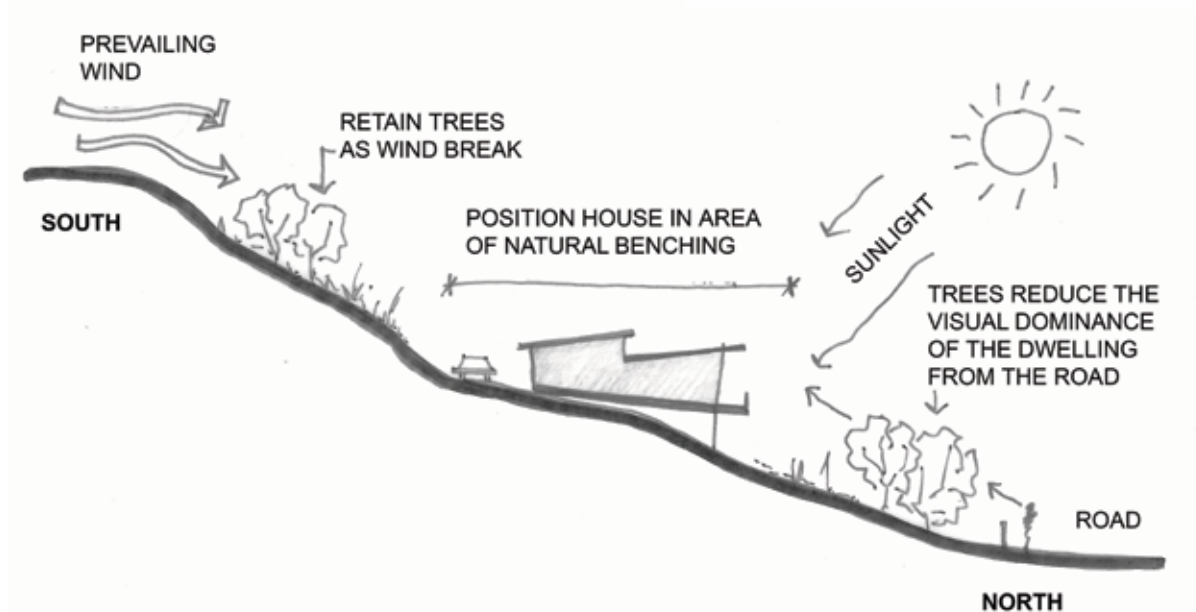
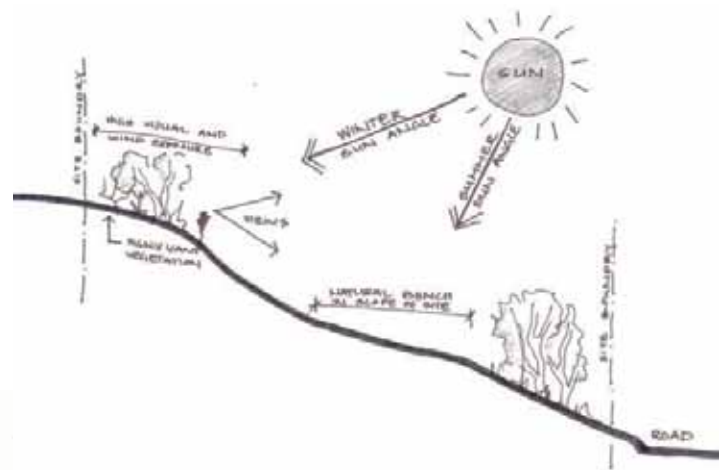

Integrated design utilises aspect, topography and existing vegetation to help determine appropriate siting of your dwelling

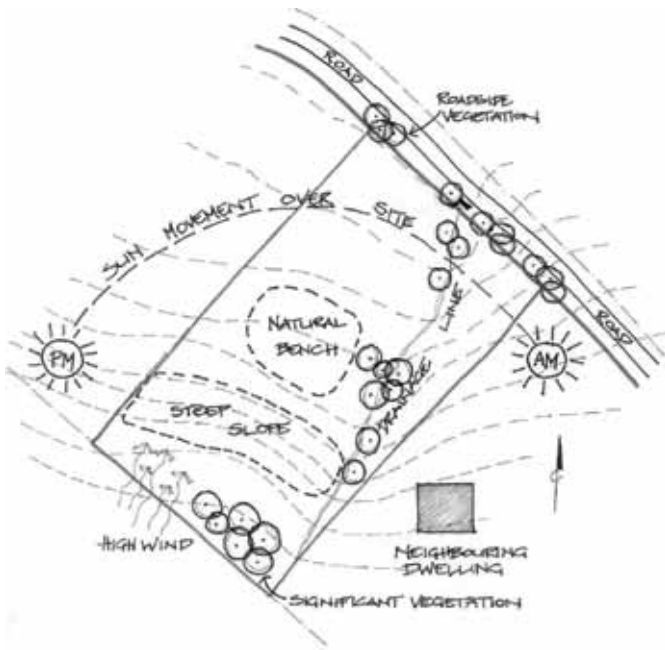

Existing site conditions and identification of natural systems

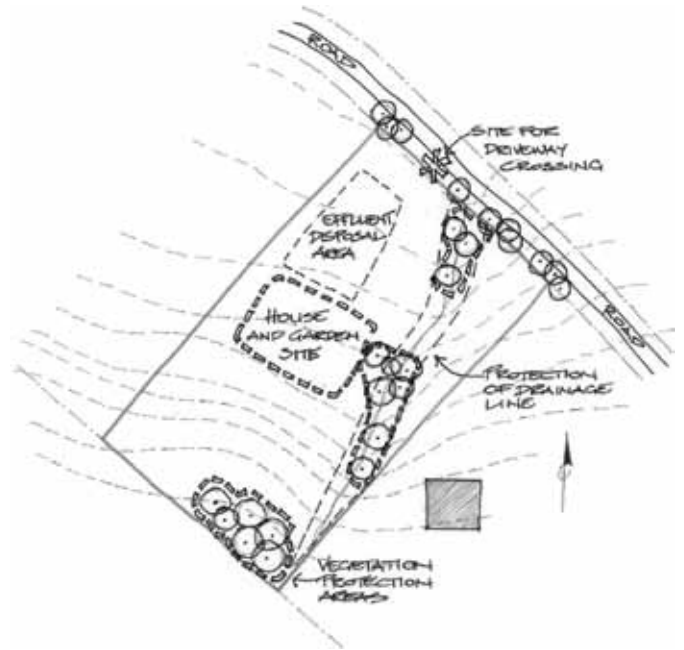

Preliminary design and layout of site

STANDARDS

- A site analysis plan must be submitted with the application, showing the proposed development in relation to all existing features and conditions (*refer to Section 8 'Application Requirements' for the details and information that should be included in a Site Analysis Plan*).
- All buildings and works, including effluent systems must be designed and sited to respond to environmental and landscape features, environmental hazards, landform and orientation.
- The development footprint should be minimised by locating the primary dwelling and outbuildings in close proximity, unless an alternate location would result in a better environmental outcome and/or reduced visual impact.

HINTS AND TIPS

- The site analysis plan needs to be to scale and should show the development opportunities and constraints on the site. This should guide the final location and design of the various development features proposed.
- Marking out the proposed development features on the site may expose new opportunities and constraints that could be added to the site analysis and give further insight into the development's relationship to the site.
- Building orientation should maximise passive heating, cooling and light.

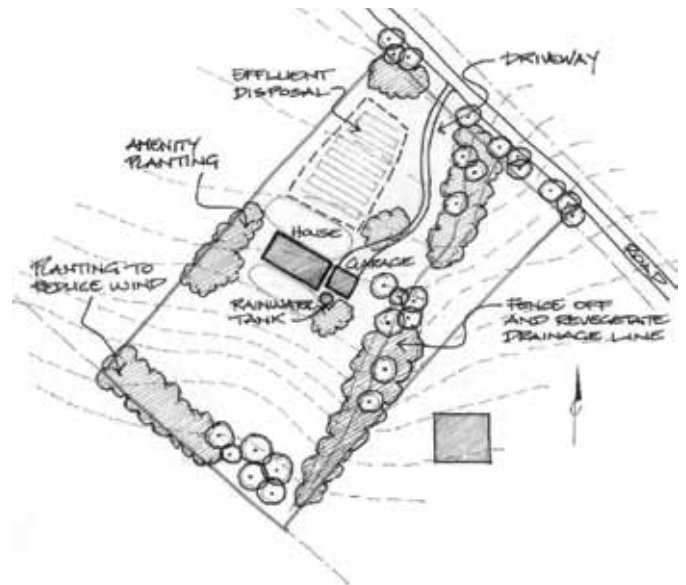

Proposed siting of development features with respect to existing site conditions

MINIMISING VISUAL IMPACT AND INTRUSION

OBJECTIVES

3. To encourage development that is in keeping with the character and appearance of the environmental characteristics of the area.
4. To ensure that developments including buildings and driveways are designed and sited so that they are not visually prominent or intrusive.

STANDARDS

- Development features must be sited to avoid the loss of indigenous, and other significant vegetation.
- Building form should seek to be subservient to the landscape to maintain vegetation dominated vistas and bushland character.
- Development should not protrude above the prevailing height of the tree canopy.
- Avoid the siting of building and works on ridgelines and exposed slopes.
- Materials and finishes should be of muted tones to complement the landscape character.
- Incorporate screening treatments to minimise the visual impact of buildings and works.

HINTS AND TIPS

- Generally the visual impacts of housing and development are softened by vegetation cover.
- Sensitive development siting and the use of a low profile, articulated roof form can ensure a less conspicuous and more appropriate housing style for a bushland site.
- By responding to site opportunities and constraints with a sensitive building form and location, a development is more likely to blend into the landscape, helping to maintain the unique bushland character of a site.
- Seek assistance from Council officers to determine the best location of new driveway entrances.
- Houses, garages, sheds, shelters and other out-buildings should not be visually intrusive when viewed from the street or neighbouring properties, roads or open space.



Developments blending with the landscape help maintain unique bushland character

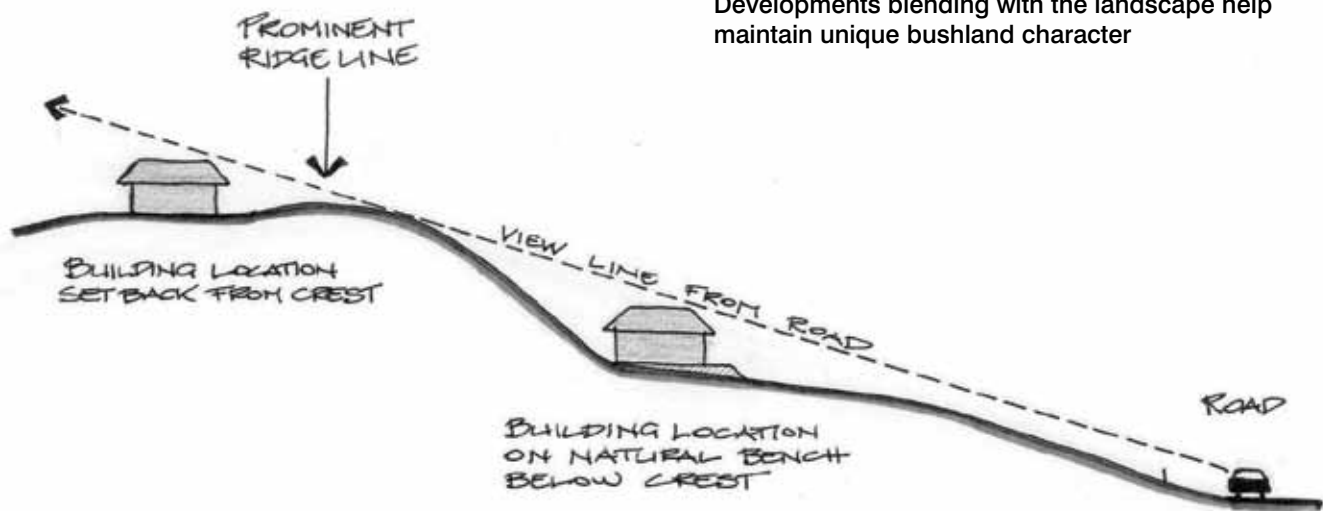

Avoid locating building and works on ridgelines and exposed slopes

AVOIDING AND MINIMISING EARTHWORKS

(also refer to section on Earthworks, page 13)

OBJECTIVES

5. To avoid or minimise the need for and extent of earthworks. Avoid the siting of buildings and works on land with slopes greater than 20 per cent.

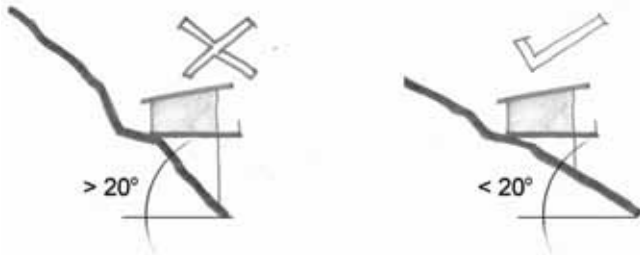

STANDARDS

- Avoid the siting of buildings and works on land with slopes greater than 20 per cent.
- All buildings and works must be sited to respond to the slope of the land and to align with the contours of the site in order to minimise earthworks.

HINTS AND TIPS

- Carefully consider the location of the development features. Site planning may minimise earthworks and avoid the need for vegetation removal.
- Housing sites requiring extensive earthworks can leave large cut or fill batters that are difficult to look after.
- Position main dwelling, sheds and outbuildings in an area of natural benching or in flat areas where earthworks can be minimised.

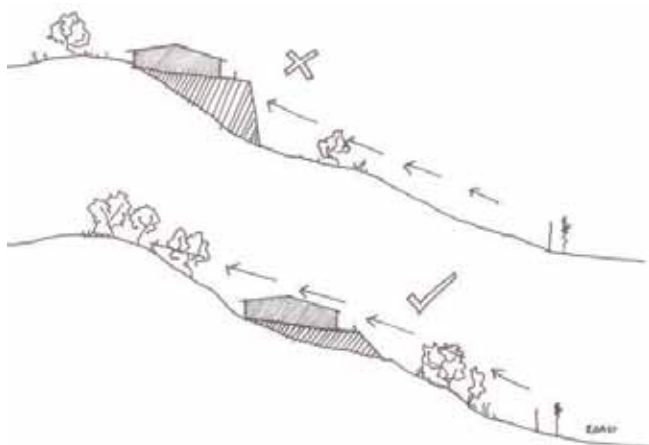

TENNIS COURTS AND SWIMMING POOLS

OBJECTIVES

6. To ensure that tennis courts and swimming pools are only sited in appropriate locations.



Tennis courts and other developments should not be visually intrusive when viewed from the street

STANDARDS

- Tennis courts and other development features should not be visually intrusive when viewed from the street.
- Avoid locating tennis courts and swimming pools on land that has a slope greater than 20 per cent.
- Tennis courts and swimming pools must be orientated to make use of slope and other natural features including:
 - Orientation of benching to be aligned with contours on land with a slope greater than 10 per cent
 - Selection of site and surface levels must seek to balance cut and fill.

HINTS AND TIPS

- Tennis courts with a north-south orientation will not be possible on all sites.
- Ensure compliance with the Code of Practice - Private Tennis Court Development.
- Some properties may not have a suitably flat site, devoid enough of vegetation, to allow the construction of a tennis court and/or swimming pool.
- A pre-application meeting with a Council planning officer will assist in determining where and whether a tennis court and/or swimming pool can be achieved on your property.

3. VEGETATION



OVERVIEW

THE IMPORTANCE OF NATIVE VEGETATION

Native vegetation includes native trees, shrubs, grasses and groundcovers. The 'original' native vegetation that occurred naturally in Manningham before European settlement, is often referred to as our 'indigenous' vegetation. Only a little over a third of Manningham's indigenous vegetation now remains. A significant proportion of this is classified as 'threatened'. In fact almost one-third is in such poor condition that a considerable effort is required to prevent it from disappearing all together. If our native vegetation disappears, so too will the native animals which rely upon it for habitat.

Humans also rely on the benefits that our native vegetation provides. Obvious benefits include pleasant views, scenic landscapes and improved property values. Less obvious are the range of services that native vegetation provides to us, in particular by areas of natural bushland. These services include the maintenance of soil health and prevention of soil erosion, the filtering of water for healthy waterways and drinking catchments, and the supply of clean air and a stable climate.

OVERLAY/PERMIT CONTROLS

Those areas of Manningham that retain a cover of native vegetation have been mapped and are protected by a range of Environmental Significance Overlays (ESOs) and Significant Landscape Overlays (SLOs). These overlays almost always require landowners to obtain a planning permit before you can remove or destroy any native vegetation (as well as permits for buildings and earthworks). Some overlays also require a permit for the removal of any 'exotic' or non-native vegetation. Before you remove any vegetation check with Council to find out if you need a permit.





THE 'NET GAIN' PROCESS

If a permit is needed for the removal of native vegetation, both the State Government and Council require that you follow a three step process. This is often called the 'Net Gain' process. Net Gain is a State Government policy that aims to reverse the decline in native vegetation cover. It means that losses of native vegetation must be 'offset' by commensurate 'gains', preferably on the same site, or elsewhere. Overall, a 'Net Gain' in native vegetation is required i.e. gains are greater than losses. Gains are achieved by protecting and improving other existing areas of native vegetation (e.g. through weed control or preventing grazing) or by planting new indigenous vegetation.

The three steps of Net Gain are:

1. **Avoid** adverse impacts on native vegetation, particularly removal
2. **Minimise** adverse impacts by planning and design
3. **Offset** all removals.

Offsets can only be considered once you have demonstrated that you have taken the first two steps, to 'Avoid' and 'Minimise' vegetation removal in the first instance. This can be achieved in a number of ways.

STEP 1: Avoid

- Can the purpose of the development be achieved in another way that could avoid native vegetation removal?
- How can the development be modified or altered to avoid the removal of native vegetation?
- What alternative development sites exist on the property that would avoid the need to remove native vegetation?

STEP 2: Minimise

- Can you locate the development in areas where less vegetation needs to be removed or where the vegetation is of poorer quality and lesser significance?
- Can you choose alternative construction techniques or materials to minimise damage to native vegetation?
- Can you re-design or re-orient the development so that areas of native vegetation can be retained?

STEP 3: Offset

A native vegetation offset is any works or other actions to make reparation for the loss of native vegetation arising from the removal of native vegetation. An offset may be:

- An area of existing remnant vegetation that is protected and managed
- An area that is revegetated and protected
- An area that is set aside for regeneration or restoration
- Any combination of the above.

COMPLYING WITH 'VICTORIA'S NATIVE VEGETATION MANAGEMENT – A FRAMEWORK FOR ACTION' (Net Gain)

OBJECTIVES

7. To achieve an improvement in the extent and quality of native vegetation, consistent with the goal of Net Gain as set out in Victoria's Native Vegetation Management – A Framework for Action (Department of Natural Resources and Environment 2002) by:
 - *Avoiding* the removal of native vegetation
 - *Minimising* the removal of native vegetation, if the removal of the native vegetation cannot be avoided, through appropriate planning and design
 - Appropriately *offsetting* the loss of native vegetation.
8. To protect and enhance the ecological values of 'Core' and 'Buffer' Conservation Areas.
9. To encourage the location of development within those areas that are the most degraded and devoid of native vegetation.

STANDARDS

- Demonstrate written evidence as to how the development will avoid, or if this is not possible, minimise the removal of, as well as any adverse impacts on, native vegetation.
- Appropriately offset any unavoidable losses of native vegetation.
- Identify all vegetation proposed to be removed and retained on a Site plan drawn to scale. *Refer to Section 8 'Application Requirements' for the details and information that should be included in a Site Plan.*
- Include a 'Net Gain Assessment' (NGA) of any native



Valley Grassy Forest

vegetation proposed to be removed, in accordance with Victoria's Native Vegetation – A Framework for Action. *Refer to Section 8 'Application Requirements' for the details and information that should be included in a Net Gain Assessment (NGA).*

HINTS AND TIPS

- See page 9 for an explanation of the Net Gain process.
- An ecological consultant will usually be required to assist you in preparing a response to 'Avoid', 'Minimise' and 'Offset'. This is required to determine the extent and conservation significance of any vegetation proposed to be removed, as well as appropriate offsets.
- Council can supply you with a list of ecological consultants that can do this work.

Consider the following:

Avoiding

- Can the purpose of the development be achieved in another way that could avoid native vegetation removal?
- How can the development be modified or altered to avoid the removal of native vegetation?
- What alternative development sites exist on the property that would avoid the need to remove native vegetation?

Minimising

- Can you locate the development in areas where less vegetation needs to be removed or where the vegetation is of poorer quality and lesser significance?
- Can you choose alternative construction techniques or materials to minimise damage to native vegetation?
- Can you re-design or re-orient the development so that areas of native vegetation can be retained?



Brunonia australis, Blue Pincushion flowers in Valley Grassy Forest

ENSURING THE PROTECTION OF NATURAL RESOURCES AND PROCESSES

OBJECTIVES

10. To ensure the long term sustainable management of land.
11. To protect natural resources, ecological processes, genetic diversity and ecosystem services.
12. To protect and enhance habitat corridors and ecological niches.

STANDARDS

- Ensure that any water run-off, stormwater, and piped or overland flows are directed away from areas of native vegetation and are appropriately captured, treated or dispersed so as not to cause adverse impacts on vegetation.

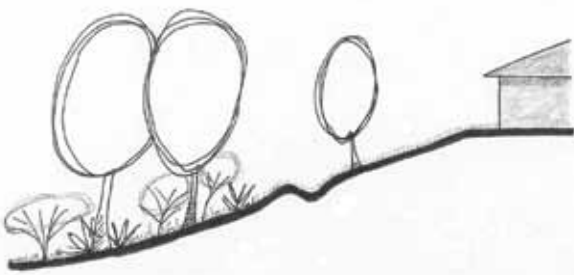

Use of swale to divert run-off away from bushland

- Include a Landscape or Revegetation plan for all proposed replanting (*refer to Section 8 'Application Requirements' for the details and information that should be included in a Landscape Plan*).

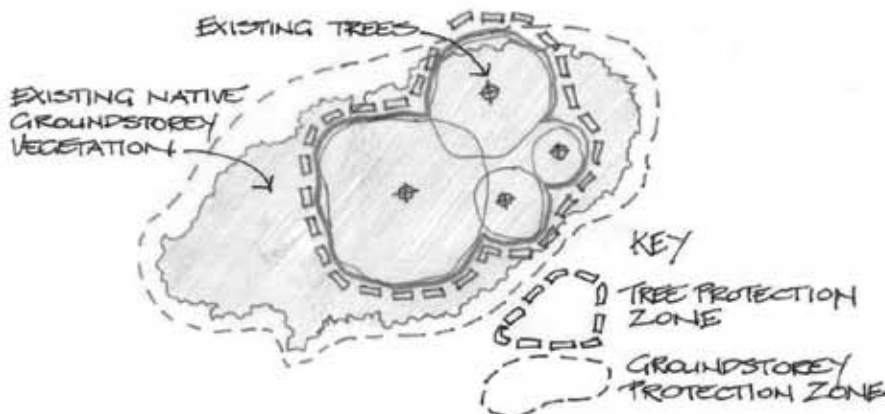

Protection of groundstorey vegetation and canopy trees is essential to maintain bushland character

HINTS AND TIPS

- Consider the native vegetation on roadside verges when planning a new driveway crossing location.
- Ask Council for advice on local plant species that could be propagated from seeds or cuttings.
- Protect retained groundstorey vegetation from water run-off as it can contain weed seeds, nutrients or sediments.

PROTECTING TREES AND LANDSCAPE/ NEIGHBOURHOOD CHARACTER

OBJECTIVES

13. To protect established canopy trees.
14. To maintain the treed character of residential and rural residential areas.
15. To retain native trees and, in some cases exotic trees for their habitat value and/or landscape contribution.

STANDARDS

- Include a surveyed plan showing all trees greater than 10cm diameter at breast height (DBH) to be removed and all to be retained which are within 10m of all developments. Show species and DBH information.
- Include an arborist's report and assessment of any trees proposed to be removed for safety or risk reasons.
- Ensure Tree Protection Zones (TPZ) are established for all trees to be retained which are over 30cm DBH and within 10m of any proposed buildings or works.

- Locate all buildings and works, including effluent envelopes to minimise the loss of or adverse impacts on, any native or other significant vegetation.
- Setback buildings from front, side and rear boundaries to provide for landscaping and for the planting of substantial indigenous canopy trees.
- New driveway crossings should be located to avoid, or if this is not possible, minimise the removal of and impacts on vegetation.
- Minimise the impact of earthworks on existing vegetation.

HINTS AND TIPS

- Site analysis and preliminary site design as well as pegging out development envelopes on site, will help to identify how close a proposed development will be to trees that are to be retained. Minor alterations to site plans can often preserve significant trees.
- Altering the ground level within the dripline of a tree may damage or kill the tree and should be avoided.



This tree protection zone does not protect the tree's critical root zone

- The use of porous paving material is encouraged wherever possible, to allow for maximum water penetration through ground surfaces to tree roots (this also minimises run-off which can cause soil erosion and can avoid the need for costly drainage systems).
- Ensure that a tree's water supply is not significantly changed through drainage works or changed overland flows.
- Wherever possible, prune trees that are in the way, rather than removing them. Carefully cut branches to avoid damage to the tree trunk, and ensure optimum healing of the cut surface. Seek specialist advice if necessary.
- The Tree Protection Zone (TPZ) should extend to at least the canopy dripline of the tree or be equivalent to 12 times the DBH of the tree, whichever is the greater. No works, soil disturbance, storage of materials, equipment or machinery, must occur within the TPZ.
- Ensure temporary fencing is erected around all TPZs. Fencing should be at least 1.3m high and of robust materials and construction such that animals, persons and/or machinery may not enter the protected zone. Star pickets with horizontal wire or hazard tape is not sufficient.

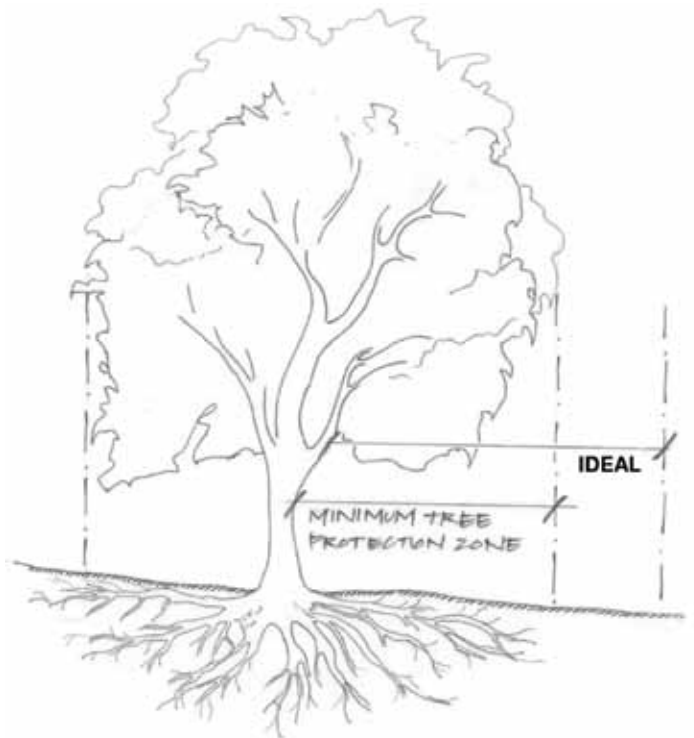

The ideal tree protection zone is one and a half times the tree's canopy width

4. EARTHWORKS

OVERVIEW

The City of Manningham has an attractive, generally undulating topography.

Development on undulating to steep sites can require earthworks, with areas of 'cut and fill' using batters and/or retaining walls to create flat surfaces. Earthworks can have a significant impact on soil stability, vegetation, native animal habitat, drainage and the general landscape character of the area. Earthworks can also impact upon your neighbour's property.

Council requires that earthworks are avoided or minimised where possible, as they can cause major disturbance both visually and ecologically.

In those parts of the municipality where slope contributes to landscape or environmental quality, there are planning controls regulating changes to the topography through earthworks.

In these areas 'overlays' specify that a planning permit is required from Council for earthworks, including excavations, the importation of 'fill' and any works that alter the natural soil levels and contours - even where these earthworks may be considered minor or are intended to provide a flat area for a house, driveway, swimming pool or tennis court.

The controls also seek to minimise the impact on neighbours and the views from roads and public open space.

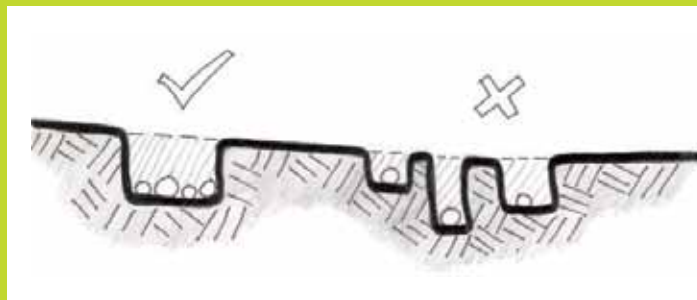

OBJECTIVE

16. To minimise earthworks through responsive siting of buildings and works.
17. To avoid and minimise the extent and environmental impact of earthworks on soils, vegetation, waterways and drainage lines.
18. To minimise the visual impact of earthworks on the landscape character of an area.

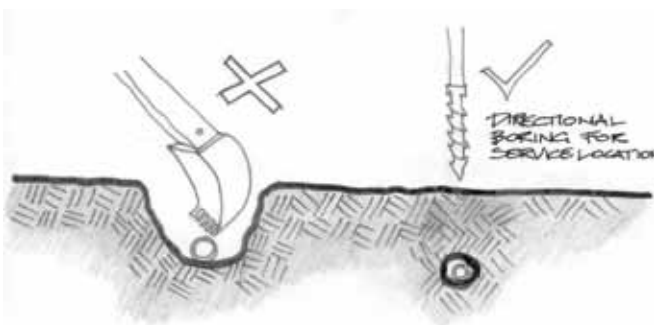

Directional boring will minimise earthworks

STANDARDS

- Development should be designed and sited to avoid and minimise earthworks.
- Buildings and works should be sited on the flattest part of a site and be designed to follow existing contours wherever possible.
- Buildings should be 'stepped' to reflect the natural topography.
- Earthworks must aim to balance the amount of cut and fill on a site to avoid the need to import fill or remove excavated material.
- Avoid earthworks on slopes greater than 20 per cent.
- The maximum permissible gradient in the following situations is:

Driveways:

- Maximum 20 per cent slope or one in five, with 12 per cent or one in eight transitions (desirable = 7 per cent slope or one in 14)

Planted embankments:

- Maximum 50 per cent slope or one in two (desirable = 33 per cent or one in three)

Grassed embankments:

- Maximum 33 per cent slope or one in three (desirable = 20 per cent or one in five)

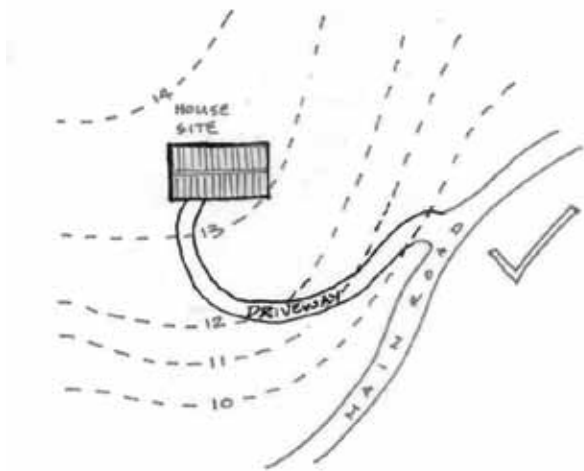
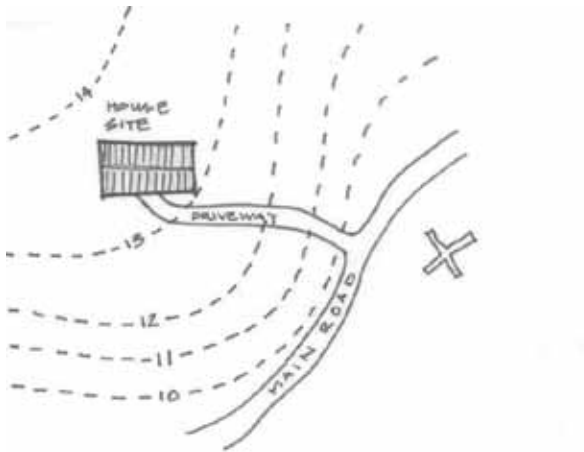

Utilise contours when building driveways

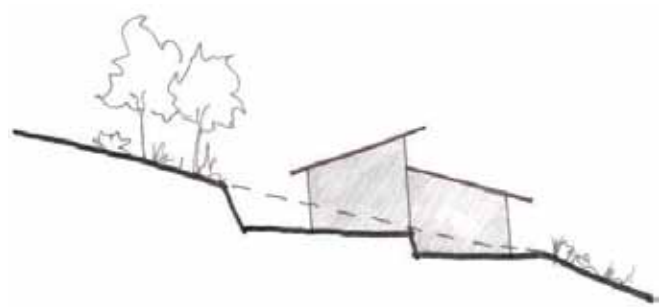

Excessive batters are hard to manage and are susceptible to erosion

- Embankments or batters in excess of 50 per cent slope or one in two, must be appropriately stabilised with retaining walls or rock boulders with geotextile matting and/or mulch.
- Filling or excavating natural drainage lines or waterways must be avoided.
- Retaining walls or embankments over 1m high should be 'stepped' or 'terraced'.
- Earthworks, excavations and fill must not occur within the critical root zone of trees to be retained.
- Tree protection fencing must be erected around the protected root zone of trees to be retained, during the construction period.
- Bare soil areas particularly embankments and batters must be protected from soil erosion by erosion control matting and/or sediment fencing, during and after the works period, until those areas have stabilised.
- Appropriate site management must ensure that no soils, sediments or silt leaves the site or enters waterways, water bodies, drainage lines or neighbouring properties.
- The construction of dams is generally discouraged but may be considered where evidence as to the sustainability and appropriateness of the dam structure is detailed in a report and plans prepared by a suitably qualified hydrological engineer.

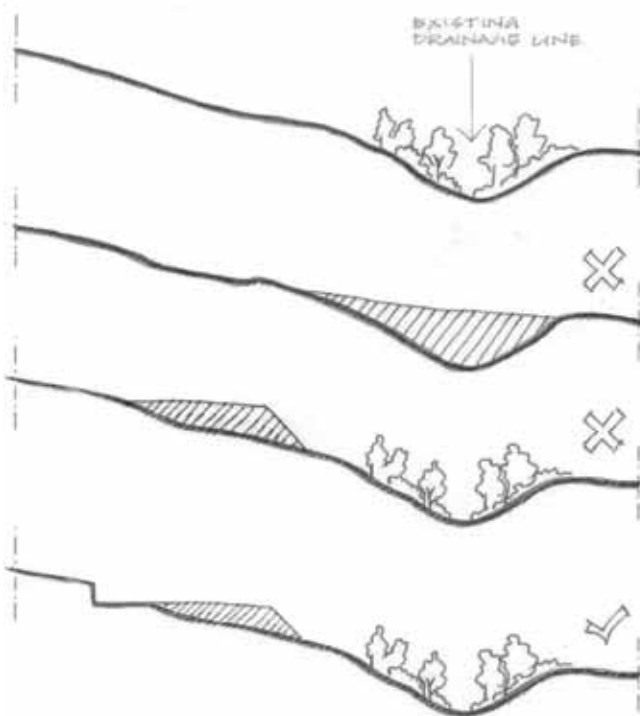

Protect gully line vegetation and reduce sediment deposits using appropriate cut and fill techniques

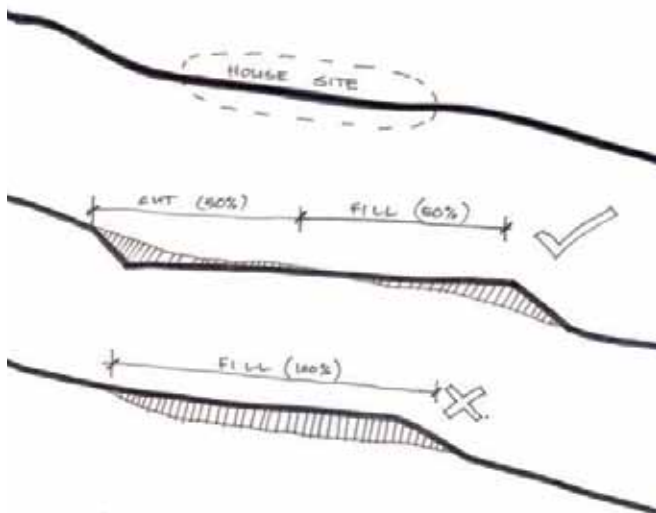

- An application involving the decommissioning of a dam must provide written documentation as to the sustainability and appropriateness of the procedures and processes proposed, detailed in a report and on plans prepared by a suitably qualified hydrological engineer.
- An application for earthworks must be accompanied by a suitably detailed site plan. Refer to Section 8 'Application Requirements' for the details and information that should be included in a Landscape Plan.

HINTS AND TIPS

- Some of the ways earthworks can be minimised include:
 - Design buildings to be 'split level' or to have 'post and beam' construction
 - Orientate benching to be parallel with contours on land with a slope greater than 10 per cent
 - Design floor levels that balance the amount of 'cut and fill' required
 - Locate entry points and driveways to follow or parallel natural contours.
 - Use natural benches or flat areas in the landform to site buildings.
- The Site Analysis Plan, along with pegging out the extent of the development on a site, will help to locate development features to avoid the need to excavate.
- On sloping sites split-level or pole construction dwelling designs are strongly encouraged.
- Create a visual feature out of a gully or wet area by revegetating it with local (indigenous) plant species.
- A Tree Protection Zone (TPZ) with a radius equivalent to approximately 12 times the diameter of the tree trunk, should be established around trees to be retained.



This tree protection zone has not protected the critical root zone. The Candlebark trees will not survive this excavation



Retaining wall secures the cut and reduces erosion

- Council may specify and require that the TPZ around trees to be retained is temporarily fenced off to avoid earthworks, building materials storage and vehicle access occurring in the protected root zone during the works period.
- Altering the slope of your land changes the natural flow of water over the site and this can cause ponding, flooding and create boggy areas.

- When excavating soil or importing fill you can substantially reduce the area of land available for on-site effluent disposal.
- Disturbed soil areas create the opportunity for weeds to establish. Importation of fill also increases the potential for weeds to be transferred onto your property from other areas.
- Earthworks and vegetation removal should not be undertaken during wet weather conditions.
- Landscape treatments such as low retaining walls, landscape rock and dense soil binding planting should be used to minimise the visual impact of earthworks and control bank erosion.
- Earthworks and retaining walls should be designed and supervised by a suitably qualified engineer with consideration to stability of cut and fill batters, soil type, compaction standards and finished treatments.
- Use biodegradable netting or 'chicken wire' to retain mulch on steeper slopes. Also consider 'hydro-seeding' steeper slopes to quickly stabilise them and establish grass cover.
- Reduce erosion potential during building works by minimising the time that land is left in an exposed and unstable condition. Properly designed and supervised earthworks can help to avoid potentially disastrous results and costly rectification measures.
- A permit is usually not required for the minimum extent of earthworks necessary to remove warrens to control vermin, provided the works area is reinstated back to natural ground level and no native vegetation is removed or destroyed. Check with Council officers if you are intending to undertake earthworks for rabbit control.
- A variety of sediment fences and erosion control techniques are available to contain the sediment from excavation or construction works on a site. Further information can be obtained from Council's Drainage Engineer or Environmental Planner or refer to *Section 9 'Further Information, Resources & Contacts'*.
- Council has a Building Over Easements Policy. If a written request is made to build or undertake earthworks within easements it shall be assessed by this policy. A copy of the policy may be obtained from Council.
- The successful planning, design, and construction (or decommissioning) of a dam depends not only on the application of sound principles or guidelines, but also on a combination of technical factors which are peculiar to that site and will generally not be apparent in their entirety or full significance to persons other than professionals. For all applications involving dams, expert advice must be sought.
- Legal requirements that affect dams in addition to the need for a Council planning permit, may include:
 - Take and Use Licence for all irrigation and commercial dams (dams used for domestic and stock purposes built on your property do not require a Take and Use Licence)
 - Construction and Operating Licence (also known as a Works Licence) for dams that fall into certain categories.



Vegetation around dams can reduce evaporation and erosion when appropriately designed



Reduce erosion at stock entry points with rocks of varying sizes



Poor example of development, using excessive fill



5. BUILT FORM AND SUSTAINABLE DEVELOPMENT

OVERVIEW

Manningham Council is committed to Ecologically Sustainable Development (ESD), which recognises, values and protects the natural environment and ecological process on which life depends both now and in the future.

Inappropriate or insensitive designs and construction methods often produce buildings and spaces that negatively impact on the environment. This can result in buildings that are more expensive to run and maintain and contribute to excessive resource consumption, waste generation and pollution.

Council supports and encourages land use planning and development, design and construction using ESD principles. Key ESD principles include energy conservation, water conservation, protecting human health, and protecting and enhancing the built, natural and cultural environments. ESD initiatives should incorporate current best practice, emerging technology and continuous innovation. Sustainable buildings and designs have a reduced impact on the environment both during their construction and over the extent of their life. Sustainable homes are also more comfortable, are healthier to live in and more cost effective to run.

High quality built form can also help to maintain the 'unspoiled' natural qualities of an area by minimising visual impacts and encouraging development that compliments the existing landscape character.

An increasing concern about and appreciation of environmental issues also means that buildings and developments with minimal or positive environmental impacts and features, have a higher market value and are more attractive to prospective purchasers.

THE 6 STAR STANDARD

From 1 May 2011, all new homes, home renovations, alterations and additions are required to comply with a 6-Star standard. The 6-Star standard applies to the thermal performance of a home, renovation or addition; plus the installation of either a solar hot water system or a rainwater tank for toilet flushing. The 6-Star requirements include efficiency standards for lighting but not plug in appliances. Meeting 6-Star compliance is not difficult; it is about good design, particularly at the planning stages. Carefully selecting your site so your home's orientation takes advantage of solar energy can add up to 1-Star to the rating.

A 6-Star rated home is projected to use 24 per cent less energy through heating and cooling compared to a 5-Star rated home. This will see a saving of about \$100 off energy bills each year. This is an average saving; residents who use the energy features in their home wisely will save even more. A building designer will be able to advise you on how to achieve this. Ask your builder for design options that go beyond minimum regulatory requirements, it will pay in the long run.

In April 2009 the Council of Australian Governments (COAG) agreed, subject to regulatory impact assessment requirements, to introduce a mandatory disclosure scheme across Australia to provide information about the energy, greenhouse and water performance of homes at point of sale or lease. The Victorian Government is committed to supporting an effective scheme for Victorian households. This scheme will require homeowners that sell or rent houses, flats and apartments to provide information to prospective purchasers and renters about the energy, water and greenhouse performance of the home, following a standard approach. The scheme is still under review and is expected to commence in the future. Therefore, it makes sense to build new homes to high environmental standards as they are likely to have a higher value, be more sought after by future buyers and in effect be 'future-proofed'.

For more information about these requirements, including how the regulations apply to additions and renovations, refer to the Building Commission of Victoria's website, www.buildingcommission.com.au or refer to *Section 9 'Further Information, Resources and Contacts'*.

BUILT FORM AND VISUAL IMPACT

OBJECTIVES

19. To ensure that the natural landscape, topography and environmental amenity are maintained as the dominant elements of the area.
20. To ensure that buildings are responsive to and sympathetic with the environmental and landscape characteristics of the area.
21. To minimise the visual impact of development. To ensure that external lighting is minimised and does not adversely impact on natural values or environmental amenity.

STANDARDS

- Buildings should be designed to step with the land to reduce the visual mass and bulk of the building.
- Avoid siting buildings on the crest of hills and ridges to preserve the existing visual character of ridge lines.

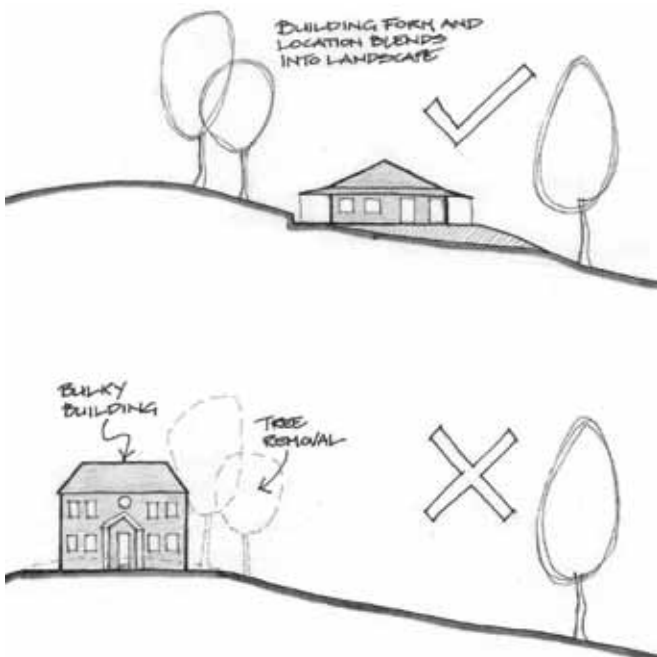

- Buildings should be oriented with respect to slopes and natural features, to reduce building bulk.
- Developments should not extend above the existing or proposed tree canopy height.

- The roof line should reflect the land form and not interfere with the ridge lines or have pitches greater than 40 degrees.



- Non-reflective external building finishes with muted tone colours to complement the natural landscape.
- External lighting should be fitted with cut-off luminaires to prevent emission of direct light into adjoining properties or natural areas.
- Fencing design, location and materials should not be visually intrusive.

HINTS AND TIPS

- To help integrate development features with natural assets, observe good examples of what other properties have done and use their example to help you achieve a better design.
- Do not commit yourself to a floor plan or site location for a dwelling or major development feature without first carefully inspecting the site with the proposal in mind.
- Avoid using catalogue floor plans and reproduction style buildings that have not been designed with the specific characteristics of your site in mind.
- Minimise the height of buildings over one storey by incorporating a second storey into the roof space.
- External lighting should be for wayfinding only and not decorative purposes.
- Look to incorporate colours and textures from the local environment and existing natural landscapes into your colour scheme and external finishings.
- Low, horizontal building forms are encouraged.

ENERGY EFFICIENCY

OBJECTIVES

22. To encourage new developments that meet or exceed best practice energy efficiency standards.
23. To ensure buildings are sited and oriented to maximise solar gain and capitalise on passive energy opportunities.
24. To encourage building designs that reduce non-renewable energy demand and harmful emissions.

STANDARDS

- The site analysis should maximise use of the sun and wind in building design, siting and orientation to reduce energy demand and greenhouse gas emissions.
- Windows and openings in the building fabric should be oriented to:
 - Optimise solar gain and/or utilise external shading where appropriate
 - Minimise the need for artificial lighting
 - Provide passive ventilation and air flows for cooling.
- Building insulation and seals on openings are installed to minimise energy consumption.
- Building materials are selected that maximise heat retention in winter and reflect heat and optimise cooling in summer.

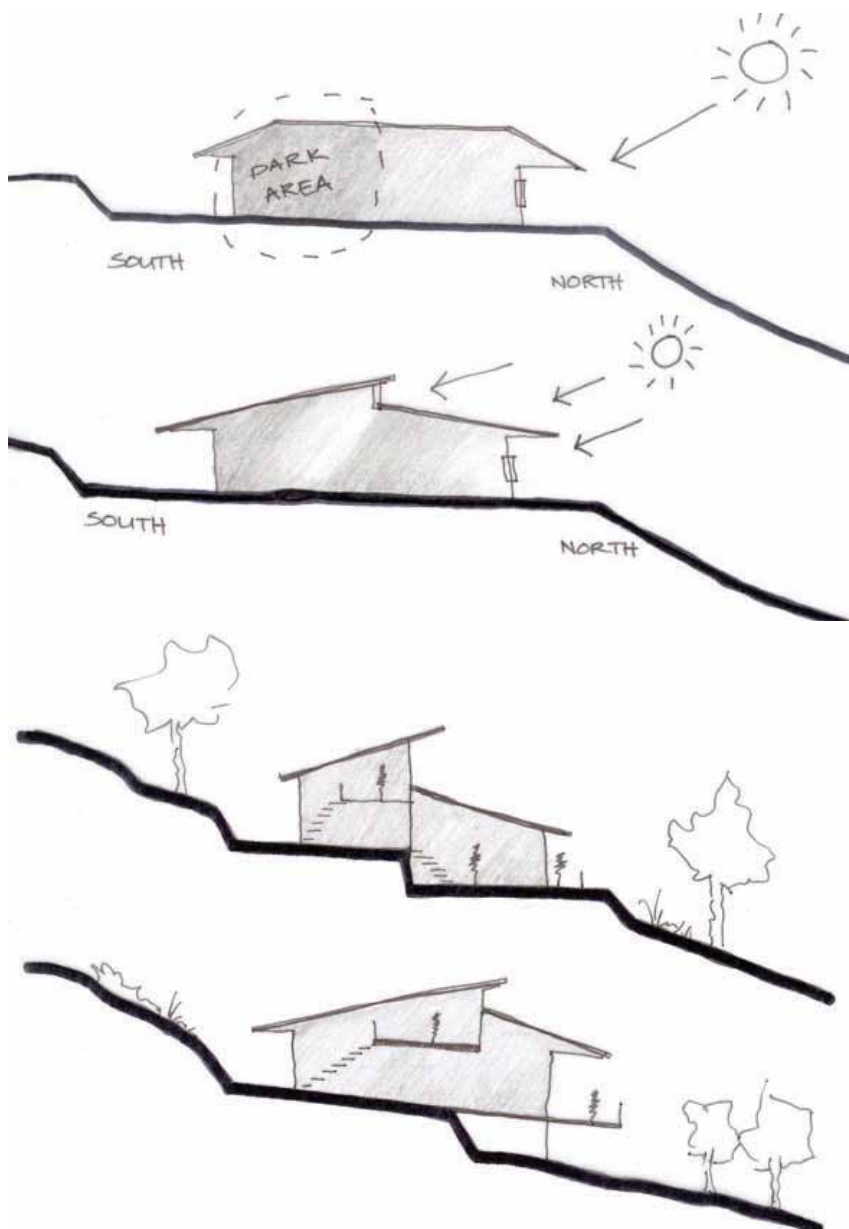

HINTS AND TIPS

- Energy efficient homes are more comfortable to live in, require less heating and cooling and are therefore cheaper to run.
- By improving your homes energy efficiency you will be improving its market value into the future.
- Temperate climates like Manningham's generally suit compact building forms with good insulation. Balance openings for solar input in winter with shading to avoid summer overheating.
- Spaces that are most used should be grouped to the north for natural light and winter heating.

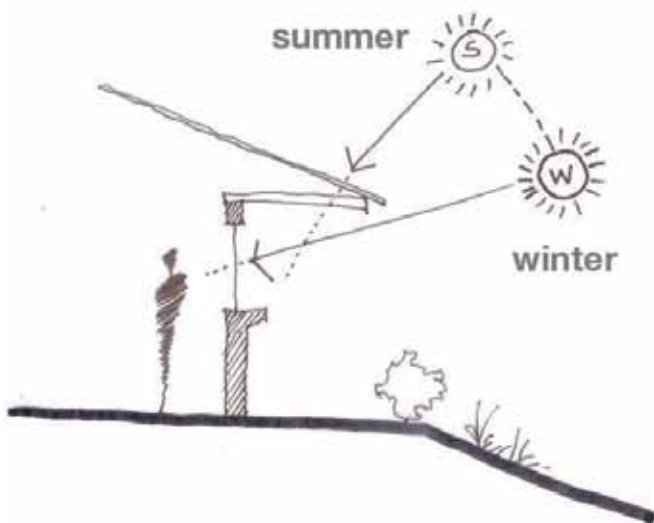

Eaves should allow winter sun and shade in summer

- Maximise the amount of direct sun in winter and protect against heat in summer by facing living rooms and windows to the north. Limit east, west and south facing windows or ensure they can be well shaded. Shading may include vegetation, external louvers or blinds, structural overhangs, perforated screens or glazing treatments.
- Install windows that can be opened to allow for natural ventilation and design for cross ventilation.

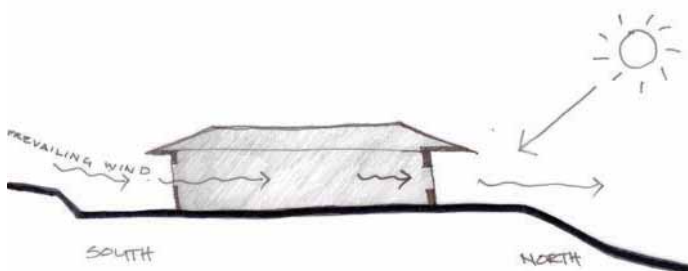

Align the house to take advantage of prevailing winds

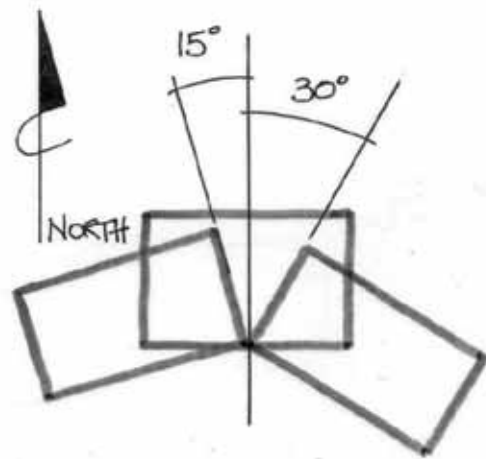

North to north-east orientations of dwellings maximise solar access and ventilation for your dwelling

- Offsetting and 'staggering' of buildings in site planning and the introduction of north-northeast orientations can maximise solar access and site ventilation. Orientation off north is preferably between 15° west and 30° east.
- Water heating generates 25 per cent of Victorian households greenhouse gasses, consider the installation of solar hot water or heat pump system.
- Install zoned heating or cooling systems rather than central systems so you are not forced to heat or cool rooms you are not using.
- Purchase and install energy efficient appliances and lighting systems – look for energy rating labels to compare products.
- The Federal and State Government offer a range of subsidies and discounts for purchasing energy efficient products and technologies.
- Contact Council for more information, advice and assistance about energy efficiency and how to reduce your greenhouse gas emissions.

WATER CONSERVATION

OBJECTIVES

25. To treat, minimise the quantity and retard the flow of, stormwater discharging from developed areas.
26. To encourage the adoption of technologies and devices which reduce potable water consumption as part of any development.
27. To retain, create or enhance vegetated buffer zones at least 30m wide along natural drainage lines and waterways.

STANDARDS

- The installation of water fittings and appliances with high water conservation ratings is encouraged.
- The installation of rainwater tanks, grey-water systems and 'rain gardens' is encouraged.
- Vegetation removal within 30m of a drainage line, waterway or water body should be avoided.
- Where appropriate native vegetation should be protected, planted and/or enhanced within 30m of a drainage line, waterway or water body.

HINTS AND TIPS

- Of all the water consumed in the home, around 10 per cent is used in the kitchen, 15-20 per cent in the laundry, and around 40 per cent in bathrooms and by toilets.
- Water fittings and appliances should have at least a 4-star water conservation rating. Information on the water efficiency of appliances can be found at the WELS website at www.waterrating.gov.au.
- Up to 50 per cent of domestic water use can be used on gardens and lawns. Minimise water usage in the garden by reducing the size of lawn areas and by planting locally native plants and grasses.
- Install a rainwater tank and use for toilet flushing and gardens.
- The Federal and State Government offer a range of subsidies and discounts for purchasing water efficient products and technologies.
- Contact Council for more information, advice and assistance about water efficiency and how to reduce your potable water consumption.

SUSTAINABLE MATERIALS

OBJECTIVES

- 28. To encourage and promote built form outcomes that demonstrate the use of building techniques that incorporate ecologically sustainable design principles.**
- 29. To encourage ecologically sustainable development principles and techniques to be incorporated into the design, construction and operation/occupancy stages of new development.**

STANDARDS

- The use of building materials that minimise ecological or health impacts is encouraged.
- The use of materials that can be expected to endure for the life of the development and can be recycled at the end of their useful life is encouraged.
- The reuse of recycled materials and the use of materials with recycled components is encouraged.
- The use of locally manufactured materials and products is encouraged.
- The use of pre-fabricated, pre-cut and standardised components to reduce waste is encouraged.
- The use of materials with low levels of toxic chemicals, minimal off-gassing and production of allergens and other internal air pollutants is encouraged.

HINTS AND TIPS

- Are you using more than your fair share of resources? If everyone on earth lived and consumed like a 'typical' Australian, we would need about four planets like earth to sustain human life.
- In Victoria, approximately 40 per cent of landfill is derived from construction and demolition waste, equating to approximately 5.6 megatonnes.
- Our buildings are damaging our health - modern buildings are such significant emitters of a range of chemicals that a 2002 Clean Air Society of Australia and New Zealand (CASANZ) report found *'There is a clear and present danger. A significant proportion of our community is at risk, and will remain at risk until the governments of Australia tackle issues which affect the quality of air within the buildings where we work, live and study... by calculation the health of millions of people is being impaired by indoor air pollution.'* Research shows that indoor air quality is often between 10 and 200 times worse than outdoor air (CASANZ).
- Avoid materials that contain volatile organic compounds (VOCs) which can impact on your health by causing irritation and allergies. Such products include many synthetic floor coverings and particleboards manufactured with toxic glues (e.g. MDF timbers).
- Low or Zero VOC paints are available from most mainstream paint retailers and paint companies.
- If your garage is attached to the house make sure there is a sealable door between the house and garage. Exhaust fumes from cars contains fine particles and toxic gases such as carbon monoxide.

6. INTEGRATED WATER MANAGEMENT

OVERVIEW

Integrated Water Management (IWM) looks at management of the water cycle as a whole system, including the key elements of potable water supply, sewage, recycled/reused water and stormwater management. IWM aims to integrate all the aspects of water relating to your site or development to achieve better environmental, social and economic outcomes. These aspects might include selecting a suitable sewage or septic system, rainwater harvesting, using recycled water and incorporating Water Sensitive Urban Design (WSUD) elements such as a 'raingarden' or porous paving (see below 'What is WSUD?').

STORMWATER

Stormwater or 'Urban Run-off' is generated by rain running off roofs, driveways, paving and other compacted or hard surfaces. It can also be generated by irrigation run-off or run-off from other domestic water use. Poorly managed stormwater can cause erosion problems on and off site and can also pollute our creeks and waterways by carrying sediments and chemicals. Appropriate management of stormwater is therefore an important element of ensuring sustainable IWM and minimising erosion. Management of stormwater must be considered as part of your development application to ensure that all planning, safety and environmental standards are met. Council and the Environmental Protection Authority (EPA) can issue fines if poorly managed or polluted stormwater is allowed to discharge from your site.

SEWERAGE AND SEPTIC

Some areas in Manningham lack a reticulated sewerage system. In these areas effluent will need to be disposed of to an EPA approved septic system. Only EPA approved systems may be installed and each item of the system should have a certificate of approval from the EPA. An Effluent Disposal Area (usually defined as an 'effluent envelope') may be required to safely dispose of liquid effluents from the septic system. The size of the Effluent Disposal Area is dependent on the number of household plumbing fixtures, bedrooms, and people living there. Poorly designed or maintained effluent disposal systems can create odours, be a significant health threat to you, your family and neighbours, and pollute the environment, especially waterways. Effluent disposal systems need to be considered early on, as part of your integrated site development planning.

DRINKING WATER SUPPLY

In Manningham, new developments will be able to connect to the reticulated, or 'mains', water supply.

The supply of drinking water in this way must be designed and constructed in accordance with the requirements and to the satisfaction of the relevant guidelines. You will need to provide Council with evidence of compliance with the requirements of the water authority. For your building permit you may also choose to, or be required to, have a water tank – Council strongly encourages this. Usually tanks will be connected to laundries, toilets or garden irrigation systems to reduce the use of 'potable' (safe to drink) water.

REUSED AND RECYCLED WATER

Council encourages you to consider reuse and recycled systems as part of your development. Substituting reused and recycled water, where fit for the purpose, can enable high levels of water savings, by reducing the demand for drinking water. Sources of reused and recycled water include wastewater or 'greywater' (when suitably treated), and urban run-off (stormwater). Recycled water must generally meet high quality standards, managed and controlled by the water authority within the regulatory framework of the EPA and Department of Human Services (DHS). For health or environmental reasons, reused and recycled water supply systems may not be appropriate in some circumstances.

WHAT IS WSUD?

WSUD stands for 'Water Sensitive Urban Design' - a best practice approach to urban stormwater management that provides for the sustainable management and improvement of the quality of water entering Melbourne's waterways from urban regions; opportunities for stormwater and greywater harvesting and reuse; and innovative reductions in potable water demand. Through collaborative efforts between councils, developers and other relevant regulatory authorities, WSUD is being incorporated into urban developments and road designs across Victoria.

KEY PRINCIPLES OF WSUD

Consistent with the *Urban Stormwater: Best Practice Environmental Management Guidelines* (CSIRO 1999), the key principles of WSUD from a stormwater management and planning perspective are:

- **Protect natural systems** – protect and enhance natural water systems (creeks, rivers, wetlands) within urban developments
- **Protect water quality** – improve the quality of water draining from urban developments into creeks, rivers and bay environments
- **Integrate stormwater treatment into the landscape** – use stormwater treatment systems in the landscape by incorporating multiple uses that will provide multiple benefits, such as water quality treatment, wildlife habitat, public open space, recreational and visual amenity for the community
- **Reduce runoff and peak flows** – reduce peak flows from urban development by on site temporary storage measures (with potential for reuse) and minimise impervious areas
- **Add value while minimising development costs** – minimise the drainage infrastructure cost of development

- **Reduce potable water demand** – use stormwater as a resource through capture and reuse for non-potable purposes (e.g. toilet flushing, garden irrigation, laundry).

WSUD ELEMENTS

WSUD elements can provide water based or natural vegetated features that add community value, while performing a treatment function through filtering of stormwater runoff. Applications can be sized up or down to suit the individual site, from a standard house block through to a whole subdivision. Appropriate planning and design will ensure successful outcomes. WSUD elements include:

- Grassed or landscaped swales
- Infiltration trenches and bio retention systems
- Wetlands
- Rainwater tanks – stormwater harvesting and reuse
- Greywater harvesting and reuse
- Rain gardens, rooftop greening, urban forests
- Porous pavements.

Acknowledgment: information adapted from “*Water Sensitive Urban Design (WSUD) - For large scale developments or small scale/one off projects*” a brochure and joint initiative of Melbourne Water and Knox City Council.



Example of a raingarden

WHAT'S IN A NAME? - GREYWATER, BLACKWATER, WASTEWATER, SEWAGE OR SULLAGE?

There are a few types or categories of 'wastewater'. Some of the terms can be confusing unless you are a plumber.

Broadly, domestic wastewater can be divided into two categories:

Sewage: all wastewater including greywater and toilet waste (also known as blackwater).

Greywater: wastewater from the shower, bath, basins, washing machine, laundry troughs, and kitchen (also referred to as sullage) i.e. everything except waste water from the toilet.

It is a common misconception that greywater does not contain pathogens and that it is only sewage and blackwater that requires treatment prior to disposal or recycling. Greywater can contain pathogens that, if poorly managed, could present a risk to human health.

Please note that most greywater treatment technologies exclude kitchen wastewater due to the difficulty of treating fats, oils, grease and the high load of organic matter. Some greywater treatment technologies also exclude greywater from the laundry trough due to the potential contamination of greywater through washing of nappies, soiled clothing, paint brushes, etc.

Acknowledgment: adapted from "Code Of Practice – Onsite Wastewater Management", EPA Publication 891.1, September 2008.



Water tank with pump cover to protect the pump and reduce noise

STORMWATER/URBAN RUN-OFF

OBJECTIVES

30. To minimise increases in the quantity of stormwater run-off.
31. To treat and maximise the quality of stormwater run-off wherever possible.
32. To protect the environmental values and physical characteristics of receiving waters from degradation by run-off.
33. To ensure that streets and roads operate adequately during major storm events and provide for public safety.
34. To minimise damage to properties and inconvenience to residents from run-off.

STANDARDS

- Storm water management systems must be designed and managed in accordance with the requirements, and to the satisfaction, of the relevant drainage authority.
- Storm water management systems must be designed to meet or exceed the current best practice performance objectives for stormwater quality as contained in the *Urban Stormwater – Best Practice Environmental Management Guidelines* (Victorian Stormwater Committee 1999) as amended.



Typical pump control centre for internal house use e.g. toilet and washing machine use

- The stormwater management system should be integrated with the overall site development plan including the street and public open space networks and landscape design.
- WSUD elements are strongly encouraged as part of development applications.
- Every lot should be provided with drainage which complies with Council standards.
- Wherever possible, excess run-off should be directed to the front of the lot and discharged into the street drainage system or a legal point of discharge.
- The site analysis plan must identify all major or minor stormwater runoff paths (overland flow paths) as well as other drainage lines, waterways or water bodies on the site.
- Stormwater run-off paths must not be filled or redirected without Council consultation.
- Buildings, works or vegetation removal should not occur within 30m of a drainage line, waterway or water body.
- Buildings must be located clear of any major stormwater runoff path and floor levels must be located at least 300mm above the 100 year (ARI) flood level.
- Minimise the impact of drainage and run-off on vegetation that is to be retained by:
 - Ensuring the natural water supply to trees being retained is not significantly changed by altered drainage patterns in the vicinity of those trees or major earthworks in their root zone
 - Protecting retained indigenous groundstorey vegetation from runoff that may contain sediment, nutrients, imported topsoils or weed seeds.
- Development plans must show appropriate measures to avoid and minimise soil erosion and sediment laden run-off such as sediment fencing and silt traps.
- Development applications must detail how any bare soil areas, especially on exposed batters and slopes, will be treated to stabilise those areas and prevent erosion and sediment laden run-off. This detail is required for the construction and post-construction phases.
- On sites where the impermeable area is greater than 35 per cent of the site, an on-site stormwater detention system will be required. (Detention systems temporarily detain stormwater on site in retention tanks or subterranean pipes to reduce loading on stormwater systems after heavy rain).



Capturing stormwater can reduce sediment flows and velocity of water eroding creek and river banks. Nutrients carried to waterways can encourage undesirable algal blooms

HINTS AND TIPS

- Urban run-off needs to be managed to minimise the risk of flooding and protect receiving waters and the environment. The receiving waters can be either surface water (creeks, rivers, bays) or groundwater.
- Current best practice water quality objectives for subdivisions are:
 - 80 per cent retention of typical urban annual suspended solids load
 - 45 per cent retention of typical urban annual total phosphorus load
 - 45 per cent retention of typical urban annual total nitrogen load.
- In addition, the guidelines require a 70 per cent reduction of typical urban annual litter load.
- Consider retaining stormwater and developing it as a landscape feature by enhancing an existing watercourse or by creating a series of rock pools and ponds.
- Consult a drainage (hydrological) engineer to determine the 100 year flood levels and the impact of your proposed development on the hydrology of the site.

- Promote detention and absorption of stormwater through permeable paving, filtration trenches, swales, lawn and garden areas. This also assists in filtering stormwater before it leaves the site.
- If a Council drainage pit has not been provided on the property, or the nature strip, a drain may need to be laid through downstream properties to a suitable discharge point.
- On larger properties where a nominated point of discharge is not available, soakage pits may be used in conjunction with absorption drains where the site has the capacity to absorb stormwater flows in addition to effluent disposal. Appropriate approvals from Council will be required.
- When an excavation or 'cut' is carried out there is almost always water seepage. Water seepage can be addressed by providing appropriate drainage at the edge of the cut. This drainage should be connected to the nominated lawful point of discharge.



Hydroseeding and hay bales can be used to reduce erosion and runoff



Use sediment fences around the excavation zone to reduce turbidity of waterways

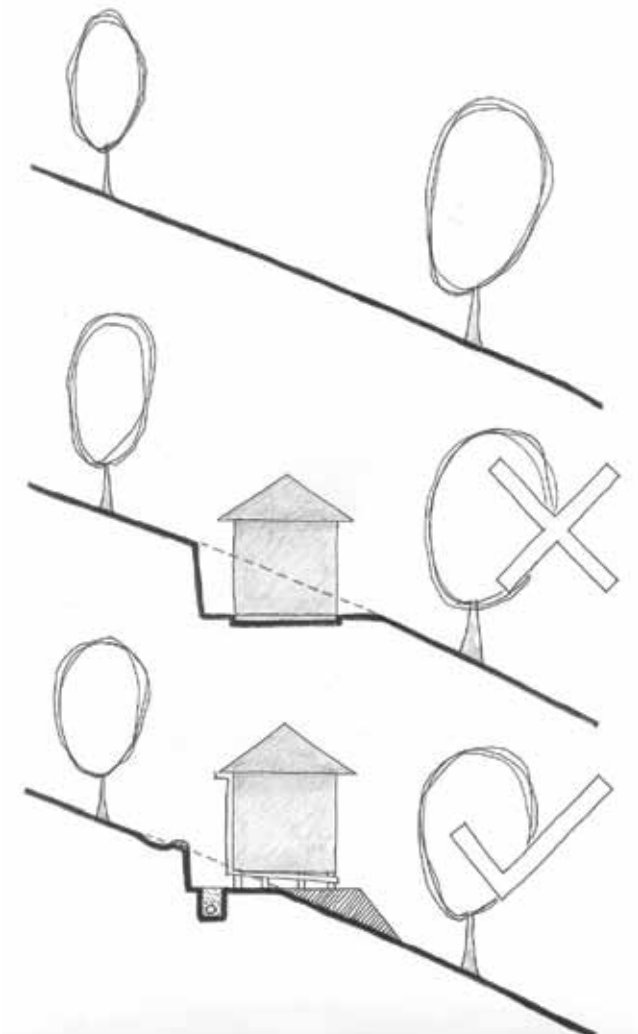

Water seepage below the cut is directed to a lawful point of discharge

- A variety of sediment fences and erosion control techniques are available to contain the sediment from excavation or construction works on a site. Further information can be obtained from Council's Drainage Engineer or Environmental Planner or refer to *Section 9 'Further Information, Resources & Contacts'*.
- Council has a Building Over Easements Policy. If a written request is made to build or undertake earthworks within easements it shall be assessed by this policy. A copy of the policy is available from Council.

SEWAGE & SEPTIC

OBJECTIVES

- 35. To provide a waste water system that is adequate for the maintenance of public health.
- 36. To provide a wastewater system that manages effluent in an environmentally sustainable manner.

STANDARDS

- On-site treatment systems are only permitted where there is no option to connect to a reticulated sewerage system.
- All applications must be in accordance with the Manningham Domestic Wastewater Management Plan.

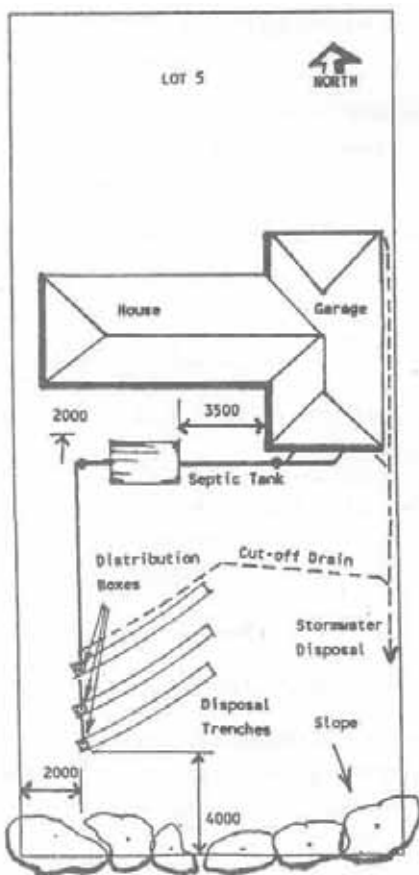

- Effluent disposal systems must comply with the *Guidelines For Environmental Management, Code Of Practice – Onsite Wastewater Management*, EPA Publication 891.1 (September 2008).
- Locate effluent envelopes to avoid and minimise environmental impacts including the loss of, or impact upon, native vegetation.
- Design effluent systems to avoid and minimise environmental impacts including the loss of, or impact upon, native vegetation.
- In unsewered areas, a Land Capability Assessment (LCA) must be undertaken to Council's satisfaction, for sites that require the installation of an onsite wastewater treatment system.
- The installation of a sink waste disposal unit (Insinkerator) is not permitted by Council.

HINTS AND TIPS

- ✓ Discuss effluent disposal requirements at an early stage in your application, with Council's Environmental Health Officer. The officer will be able to suggest who to contact to prepare a 'Land Capability Assessment' and system design.
- ✓ Applicants are strongly encouraged to read and understand the "*Guidelines For Environmental Management, Code Of Practice – Onsite Wastewater Management*", EPA Publication 891.1 (September 2008). This is available from the EPA website at www.epa.vic.org.au

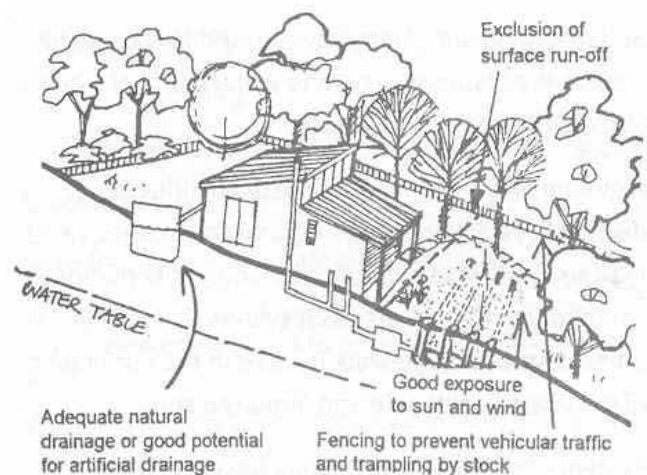

- Selecting the best wastewater treatment and disposal or recycling option for a specific site requires a thorough assessment of a number of related factors that include, but are not limited to:
 - Slope and aspect
 - Climate and rainfall
 - Soil capability (soil type, texture, depth, organic matter, sodicity)
 - Vegetation
 - Distance to boundaries
 - Type and function of adjoining properties
 - Expected wastewater volume generated.
- The site analysis should influence the location and design of any Effluent Disposal Area.
- The size of the Effluent Disposal Area is dependent on the number of household plumbing fixtures, bedrooms, and potential people living there. An area of 600m² is usually the minimum required size.

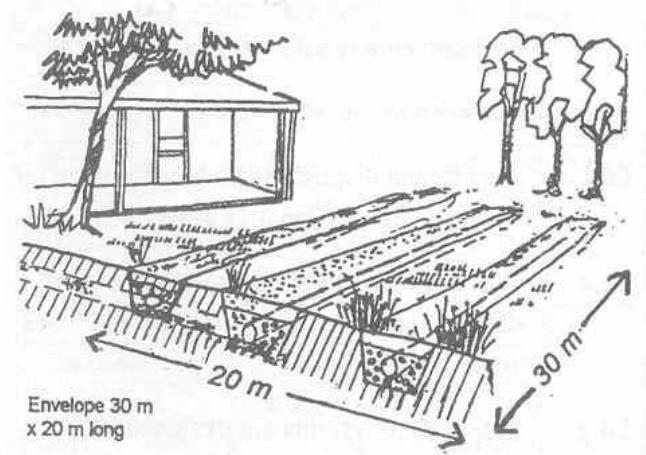

Effluent disposal area size depends on how many household plumbing fixtures and potential number of people living in the household

- Effluent absorption trenches disperse water that is high in nutrients. This can have a detrimental affect on nearby native vegetation and promotes weed growth.
- The system owner is responsible for ensuring that the onsite wastewater system is functioning at all times.
- Onsite wastewater treatment systems and associated disposal/recycling systems must be operated and maintained regularly by accredited service agents and system owners.

DRINKING WATER SUPPLY

OBJECTIVES

37. To encourage a reduction in the use of potable water.
38. To ensure an adequate, cost-effective supply of drinking water.

STANDARDS

- The supply of drinking water must be designed and constructed in accordance with the requirements, and to the satisfaction, of the relevant water authority.
- For subdivisions, the supply of drinking water must be provided to the boundary of all lots in the subdivision to the satisfaction of the relevant water authority.
- Reused and recycled water supply systems which reduce the consumption of potable water, are strongly encouraged as part of all development applications.

HINTS AND TIPS

- In Manningham, new developments will be able to connect to the reticulated, or 'mains', water supply.
- Refer to *Section 9 'Further Information, Resources and Contacts'* for information on devices and technologies that can reduce potable water use.
- Rainwater should be collected and used for non-potable water uses such as gardening, laundry use and toilet flushing.
- The Victorian Government offers rebates for installing water tanks – the higher the reduction in potable water use, the higher the rebate. *Refer to Section 9 'Further Information, Resources and Contacts'*.
- Things you need to consider when determining the size of a tank include:
 - *Rainfall* - how much rainfall you get in your area
 - *Roof area* - how large the catchment surface is
 - *Water usage* - what you intend to use rainwater for, and how much you expect to use
 - *Site characteristics* - how much space you have, and the location you intend to install the tank or storage vessel.

REUSED AND RECYCLED WATER

OBJECTIVES

- 39. To encourage the substitution of drinking water for non-drinking purposes, with reused and recycled water.**

STANDARDS

- Reused and recycled water supply systems must be designed, constructed and managed in accordance with the requirements, and to the satisfaction, of the relevant water authority, Environment Protection Authority and Department of Human Services.
- Greywater/Wastewater reuse and recycling systems must comply with the *Guidelines For Environmental Management, Code Of Practice – Onsite Wastewater Management*, EPA Publication 891.1 (September 2008).

HINTS & TIPS

- ✓ Install a greywater system to recycle the water from the laundry and kitchen in toilets and gardens.
- ✓ The Victorian Government offers rebates for installing greywater reuse systems. Refer to Section 9 'Further Information, Resources & Contacts'.



Subsurface drip line installation recycles water from your sewage system

- ✓ Untreated greywater should be reused in accordance with the most recent version of EPA Publication 884, *Greywater use around the home*, and not stored for longer than 24 hours.
- ✓ Greywater re-use options are different for sewered and unsewered areas.
- ✓ Onsite greywater treatment systems can supply *treated* greywater for certain uses. However, as these systems provide a permanent supply of greywater, and in some cases the greywater is recycled inside the house, more stringent conditions are applied to their installation and use than those applied to temporary bucketing or diversion of *untreated* greywater. A Council permit is required prior to the installation of the system. The system must be operated and maintained in accordance with the Council permit and relevant EPA Certificate of Approval (CA) to ensure that public health and the environment are protected.

OPTIONS FOR SEWAGE TREATMENT AND DISPOSAL/RECYCLING IN UNSEWERED AREAS

A number of different options are permitted for onsite treatment and land disposal or recycling of sewage in unsewered areas. These include:

- Primary treatment tanks (anaerobic or aerobic) followed by disposal via soil absorption trenches or mound systems
- Secondary treatment systems that treat wastewater to a quality that allows recycling via sub-surface irrigation or surface irrigation
- Dry composting toilets with the solid waste composted and the liquid component (urine) disposed of via soil absorption trenches, or evaporation.

The selection of the land disposal/recycling system needs to be based on the land capability of the site, the standard to which the wastewater has been treated, and the disposal/recycling systems management requirements. Council must be fully satisfied that the type of disposal/recycling system and the associated area (either soil absorption trench field or irrigation area) is appropriate. This is determined by a land capability assessment, undertaken in accordance with the most recent version of EPA Publication 746, *Land capability assessment for onsite domestic wastewater management*.

7. BUSHFIRE SAFETY – PLANNING AND BUILDING INFORMATION

OVERVIEW

If you live or work near bushland or in a well-treed location, you, your family and your house may be at risk from bushfire. This is the case in many areas of environmental and landscape significance within Manningham, particularly those areas east of the Mullum Mullum Creek, those within the designated Bushfire Prone Area and especially properties affected by the Bushfire Management Overlay (BMO). Refer to page 32 for further information on the Bushfire Management Overlay.

If you are, or intend to become, a resident in a bushfire risk area, you are strongly urged to have a written survival plan that takes into account family members, visitors and pets. If you work or intend to travel in a high-risk fire area, you are also encouraged to prepare a plan. Templates for preparing a plan are available on the CFA website, www.cfa.vic.gov.au as part of the Fire Ready Kit. The Fire Ready Kit also contains important information to help you assess the level of risk for your location, how vulnerable you are and how best to prepare your property.

All residents in Manningham should assess and understand their risk from bushfire. The fire brigade will not always be able to protect each individual property threatened by a bushfire. If you live or work in Warrandyte, Wonga Park, Park Orchards, Donvale or within the Bushfire Prone Area you should obtain a Fire Ready Kit and prepare a Bushfire Survival Plan. Hardcopies of the kits are also available by ringing the Victorian Bushfire Information Line on 1800 240 667. Please contact the CFA for further advice and assistance.

Refer to Section 9 'Further Information, Resources and Contacts'.



Bushland regenerating one year after fire

BUILDING IN A BUSHFIRE PRONE AREA

Building design and construction is a major contributor to improving your chances of surviving a bushfire. Appropriate design and construction can substantially reduce the vulnerability of a building to radiant heat, flame and ember attack. In Bushfire Prone Areas (BPA) of Manningham there are building construction requirements in place to reduce the risk. These bushfire construction requirements are aimed at improving bushfire protection for residential buildings. The creation of the designated bushfire prone areas fulfills one of the 67 recommendations made by the 2009 Victorian Bushfires Royal Commission.

Bushfire prone areas are those areas that are subject to or likely to be subject to bushfires. The Bushfire Prone Area (BPA) maps have been developed using the best available science taking into account factors such as weather, topography and vegetation. To find out if you are within the Bushfire Prone Area in Manningham, please call Council's Statutory Planning Unit on 9840 9495 or visit www.dpcd.vic.gov.au/bushfireproneareas to enter your property or address and see immediately if you are in a designated BPA.

A minimum construction standard applies to all new buildings and additions/extensions within the designated bushfire prone area. All new homes considered to be in a BPA, must be built to a minimum Bushfire Attack Level (BAL) 12.5 to help withstand ember attack. This includes sealing roofs, sealing around doors and windows and screening windows. Higher construction levels may be required as determined by the site BAL assessment.

WHAT IS A BUSHFIRE ATTACK LEVEL?

A Bushfire Attack Level is a means of measuring the severity of a building's potential exposure to ember attack, radiant heat and direct flame contact. There are six Bushfire Attack Levels (see table below) which form part of the Australian Standard for construction of buildings in bushfire prone areas (AS 3959-2009).

You should engage a suitably trained professional to assist in determining the BAL for your site. Contact Council for a list of professionals or find a Registered Building Practitioner on the 'Find an RBP' section of the Building Commission website www.buildingcommission.com.au or call the Building Practitioners Board on 1300 815 127.

| Bushfire Attack Level (BAL) | Radiant Heat Exposure (AS 3959) and levels of exposure | Description of predicted bushfire attack and levels of exposure |
|-----------------------------|---|---|
| BAL – LOW | Insignificant. If you are in a designated BPA, you must however construct to a minimum BAL 12.5 | The risk is very low, radiant heat on the building is insignificant to warrant specific construction requirements, however ember attack may still occur. |
| BAL – 12.5 | 0 to 12.5 kW/m ² | Primarily risk of ember attack; risk of radiant heat is considered low. |
| BAL – 19 | 12.5 to 19 kW/m ² | Risk is considered moderate with increasing levels of ember attack and burning debris ignited by wind borne embers; increasing likelihood of exposure to radiant heat. |
| BAL – 29 | 19 to 29 kW/m ² | Risk is considered to be high with increasing levels of ember attack and burning debris ignited by wind borne embers; increasing likelihood of exposure to radiant heat. |
| BAL – 40 | 29 to 40 kW/m ² | Risk is considered to be very high. Increasing levels of ember attack and burning debris ignited by wind borne embers; increasing likelihood of exposure to radiant heat and some direct exposure to flames possible. |
| BAL – FZ | 40 kW/m ² plus (Flame Contact) | Risk is considered to be extreme. Direct exposure to flames from fire front is likely in addition to high levels of radiant heat exposure and ember attack. |

For existing homes, the CFA and Building Commission have published a Guide to Retrofit Your Home for Better Protection from a Bushfire. The guide provides practical advice to those who wish to upgrade their existing homes to be better protected from bushfires. The guide is available on the Commission website www.buildingcommission.com.au or on the CFA website at www.cfa.vic.gov.au

THE 'BUSHFIRE MANAGEMENT OVERLAY' (BMO)

In higher risk locations within the Bushfire Prone Area, building AND planning controls are in place. These areas are covered by the 'Bushfire Management Overlay' (BMO) in the Manningham Planning Scheme. Areas in the BMO are areas that have the highest fire risk and are likely to be particularly exposed to the impact of bushfire. The suitability of new development in these areas, must be fully considered before it proceeds. Where development does occur in these areas, appropriate bushfire protection measures will be required. To find out if you are affected by the Bushfire Management Overlay, please contact Council's Statutory Planning Unit on 9840 9495 or visit www.land.vic.gov.au to obtain a report for your property that will include what overlays apply to your land.

WHAT IS THE PURPOSE OF THE BMO?

The purpose of the BMO is to:

- Identify areas where the bushfire hazard requires minimum bushfire protection measures for subdivision and buildings and works to be specified
- Ensure that the location, design and construction of development and the implementation of bushfire protection measures are considered
- Ensure that development does not proceed unless the risk to life and property from bushfire is managed to an acceptable level.

WHAT IS THE BMO?

The BMO consists of a map which shows the areas affected by the BMO and written planning controls which set out:

- The types of development that require a planning permit
- The information that must be submitted with a planning permit application

- The decision guidelines that the council must consider when they assess a planning permit application.

The planning controls are contained in clause 44.06 – 'Bushfire Management Overlay' of the Manningham Planning Scheme and can be viewed at the Manningham Council Civic Centre, 699 Doncaster Road, Doncaster or online at <http://planningschemes.dpcd.vic.gov.au>

The BMO includes some exemptions from the need to obtain a planning permit, including for an extension to an existing dwelling, provided that the floor area of the extension is less than 50 per cent of the area of the existing dwelling.

WHAT REQUIREMENTS APPLY TO PERMIT APPLICATIONS UNDER THE BMO?

The requirements for new development in the BMO are set out in clause 52.47 'Bushfire protection: planning requirements' of the Manningham Planning Scheme. This includes detailed objectives, standards, mandatory standards and decision guidelines that permit applications need to comply with. A new development must meet all of the relevant objectives of clause 52.47 and can be viewed at the Manningham Council Civic Centre, 699 Doncaster Road, Doncaster or online at <http://planningschemes.dpcd.vic.gov.au>

WHAT IS A BUSHFIRE MANAGEMENT STATEMENT?

An application under the BMO must contain a locality and site description and a 'Bushfire Management Statement'. The Bushfire Management Statement is a document prepared by or on behalf of the permit applicant and is used to determine if the requirements of the BMO have been met and whether a planning permit should be granted. The statement must contain a Bushfire Site Assessment prepared to calculate defensible space and construction requirements for new development, a report demonstrating how the application meets the relevant objectives, standards, mandatory standard and decision guidelines set out in clause 52.47.

Applicants will generally require a suitably qualified professional to prepare their Bushfire Management Statement. Please contact the CFA www.cfa.vic.gov.au or Council's Statutory Planning Unit on 9840 9495 for further information.

8. APPLICATION REQUIREMENTS

1. SITE ANALYSIS PLAN

All applications for buildings and works must be accompanied by a Site Analysis Plan. The Site Analysis Plan should show the proposed development in relation to the topography, waterways, vegetation, existing buildings, view lines and other attributes of the site. It should include all existing and proposed features on the site including, as appropriate:

- Topographic information showing contours, ridges and gullies
- Hydrological information showing drainage lines, overland flow paths, watercourses, wetlands and dams
- Slopes with a gradient of more than 20 per cent
- All proposed and existing buildings and structures including fences
- Dimensions of any building envelope with setbacks to all boundaries
- Setbacks of buildings and works to all boundaries
- Location, extent and type of vegetation on the site
- Accurate and detailed existing and proposed finished site levels
- Proposed gradient and finished level at the top and toe of all batters
- Cross sections to illustrate the extent of any cut and fill
- The location and details of any proposed retaining walls including height, materials and if required, drainage
- The location, gradient and camber of driveways and any associated earthworks
- The location, type and size of any effluent disposal system including any effluent envelope
- The location of any easements
- The location, depth and width of proposed underground services and trenches
- Full building elevations detailing wall height above natural ground level and overall height above natural ground level
- Floor plans including finished floor levels
- Proposed external building finishes and colours.

2. LANDSCAPE PLAN

The majority of landscape permit conditions require a landscape plan to be submitted prior to the commencement of the land development or prior to the completion of a subdivision.

To assist in preparing your plan, a Landscape Plan Guidelines booklet is available from Council.

As a minimum, your plan should meet the following criteria/checklist:

| ASSESSMENT CRITERIA | YES | NO | N/A |
|---|-----|----|-----|
| Is the planning permit current (check dates of permit)? | | | |
| Has the development plan been approved? | | | |
| Is the proposed landscape plan consistent with the approved development plan? (Are the locations of walls, fences, paving, stairs, clotheslines, doors and storage sheds the same?) | | | |
| Have permit conditions regarding landscaping been satisfied? (check the conditions of your permit) | | | |
| Is there a readable standard scale? (1:100, 1:200) | | | |
| Is the development property address shown? | | | |
| Are site boundaries and easements clearly indicated? | | | |
| Is there indication of the location and extent of existing vegetation to be removed? | | | |
| Is there indication of the location and extent of existing vegetation to be retained? | | | |
| Is there an accurate/reasonable indication of the mature canopy size of existing and proposed trees and shrubs? | | | |
| Is there indication of vegetation adjacent to the site, which may be relevant to the landscape design, if applicable? | | | |
| Is there a planting schedule noting botanical names, planting pot size, mature height and width, and total numbers of each species of proposed planting? | | | |
| Are local weed plants avoided in the planting schedule? (See Weed Identification Booklet for Manningham) | | | |
| Are there adequate plant densities and planting provided? (Garden beds should include planting which will provide complete coverage at maturity) | | | |
| Is there adequate provision of permeable and non-permeable surfaces, as per the approved development plan? | | | |
| Is there identification of surface treatments and features? | | | |
| Are there details and identification of garden bed edging? | | | |
| Have the proposed soil preparation and mulching treatment been detailed/noted? | | | |
| Have privacy, views and outlook been considered? | | | |
| Does the landscape plan relate and complement the existing and proposed streetscape character? | | | |

FOR ALL APPLICATIONS FOR VEGETATION REMOVAL

3. SITE PLAN

All applications for vegetation removal must be accompanied by a suitably scaled and dimensioned site plan. The plan should show the location of all site features and the vegetation proposed to be removed and retained including, as appropriate:

- The location and nature of the vegetation showing:
 - The species and size of trees
 - For native vegetation, any identified EVCs, habitat zones, 'old' and 'scattered trees'.
- Topographic information showing contours, drainage lines, watercourses, wetlands and dams
- Slopes with a gradient of more than 20 per cent
- All proposed and existing buildings and structures including fences
- Tree Protection Zones for all trees to be retained which are over 30cm DBH and within 10m of any proposed buildings or works
- Property boundaries and any building, effluent or driveway envelopes
- All proposed works including trenching and services
- The extent and gradient of any proposed slopes and batters
- The location, details and cross sections of any proposed batters, retaining walls, and areas of cut and fill, including natural and finished ground levels
- The location and extent of any Vegetation Management Zones if vegetation is to be removed for fire protection purposes.

FOR APPLICATIONS INVOLVING THE REMOVAL OF NATIVE VEGETATION

4. NET GAIN ASSESSMENT

In addition to a site plan as described above, a Net Gain Assessment will usually be required as part of an application to remove native vegetation. This is to ensure the application complies with State Government clearing controls.

The need for a Net Gain Assessment will be determined by Council in relation to the overlay controls on your property and the amount, and

conservation significance, of the native vegetation on the site. An appropriately qualified ecological consultant will need to be engaged to prepare a Net Gain Assessment, if one is required. The content of a Net Gain Assessment may vary according to the attributes of a site, but must be in accordance with *Victoria's Native Vegetation Management – A Framework For Action* and should include maps and descriptions of the vegetation, including:

- A written explanation of the steps that have been taken to avoid, minimise and offset the loss of native vegetation
- Identification and assessment of all vegetation proposed to be removed and retained, as a 'patch', 'scattered trees, or 'degraded treeless vegetation' as defined by *Victoria's Native Vegetation Management – A Framework For Action*
- The location and written description of any habitat zones or patches of native vegetation, including the:
 - Ecological Vegetation Class (EVC)
 - Habitat Hectare score
 - Conservation significance
 - Species and diameter at breast height (DBH) of any medium, large or very large old trees.
- For 'scattered trees', the location, species and size of all trees over 10cm DBH that are proposed to be removed, and any trees over 10cm DBH that are proposed to be retained and are within the building envelope, or within 10m of any proposed buildings or works
- A list of species present or likely to be present at the site including their conservation status
- Maps and details of any Vegetation Management Zone(s) required for fire protection purposes, including the assessment and offsetting of any vegetation losses associated with those zone(s)
- An assessment and condition report by an arborist of any trees proposed to be removed for safety reasons
- A description of any fauna species that are rare or threatened at the local, regional, state or national level, that have been recorded within 1.5 kilometres of the site, or which are known to be, or likely to be, present at the site including:
 - The conservation status of each species

- An assessment of the likelihood that the site provides habitat for each species and the impact of the proposal on the habitat of each species
- Actions to avoid and minimise adverse impacts.
- The quantification and description of offsets as required to comply with *Victoria's Native Vegetation Management – A Framework For Action* and the *Port Phillip and Westernport Native Vegetation Plan*, including an assessment of whether the offsets can be achieved on the site, or whether an 'off-site' offset may be required.
- An offset plan for any proposed offsets including location, implementation details and long term management and protection measures over a ten year period.

NOTE For applications involving larger or higher significance areas of native vegetation removal, Council and/or the Department of Sustainability and Environment (DSE) may require further work such as additional flora or fauna surveys, particular sampling or trapping techniques for targeted species or other special legislative or regulatory requirements.



Remnant trees with hollows for wildlife can take eighty to one hundred years to start forming

5. ARBORIST'S REPORT

In addition to any of the above, Council may require a written report by a qualified arborist to accompany an application for Tree removal. An arborist's report may be required:

- To describe the species, size and condition of tree(s) proposed to be removed
- To assess and describe the heritage and/or landscape significance of tree(s) proposed to be removed
- To minimise harm to and ensure the survival of significant trees by assessing the need for, and recommending alternative construction techniques for, a development and/or the size and location of Tree Protection Zones (TPZs) that may be required during the development period
- To assess the risk posed by, and justify the removal of, any significant tree(s) proposed to be removed for safety or hazard purposes
- To assess and recommend alternatives to significant tree removal such as bracing, lopping and pruning.

6. LAND MANAGEMENT PLAN

If your property is in a Low Density Residential (LDRZ) or Rural Conservation Zone (RCZ), Council may require you to prepare and implement a Land Management Plan (LMP), as part of your planning permit application. In these zones, a LMP will generally always be required as part of a planning permit application unless your property is less than or equal to 0.4ha in size, or in the opinion of Council the proposed works or development are minor in nature and extent.

Council Officers can assist and advise with many aspects of a LMP.

PURPOSE OF A LMP

The purpose of a LMP is to protect the environmental values of your property. These values, whilst they may originate on your land, have flow on effects and benefits for the wider community i.e. the natural assets or environmental values on your property provide a service and benefit to the wider community.

These benefits are sometimes referred to as 'ecosystem services'. Ecosystem services include:

- Maintenance of healthy waterways and potable water supplies
- Provision of shade, shelter and enjoyable landscapes
- Prevention of soil erosion and maintenance of healthy soils
- Provision of habitat for local flora and fauna
- Contribution to moderating climate change.

The aim of the LMP is to sustain the natural assets of your property and ensure that ecosystem services and values are protected and sustained for the benefit of the whole community. An additional benefit is that having a sustainably managed property may increase your property value.

CONTENT OF A LMP

Where a LMP is required, it should include the following:

A written description of your property's natural and built assets along with a scaled map/plan showing the location of these features and existing conditions including:

- Property shape and boundaries
- Contours, landscape features and soils
- Building and effluent envelopes
- Waterways, drainage lines, streams and dams
- Location of services and easements
- Water supply
- Built structures (e.g. buildings, sheds, fences, driveways, swimming pools, tennis courts)
- Indigenous vegetation
 - Extent of, quality and significance
 - Type - Ecological Vegetation Class (EVC)
 - Presence of any rare or threatened species.



Weed and rabbit infestations are typical on sites of soil dumping and disturbance

Identification and description of the hazards and threats to those assets including:

- Weeds – the distribution, abundance and status of all noxious and environmental weeds on the property needs to be determined and specific actions and priorities prescribed for each weed
- Pest animals (e.g. foxes, deer, rabbits) – indicate the extent and nature of the rabbit problem, including warren/burrow location and integrated control methods including warren closure/ destruction
- Fire – main risk areas/direction, location of water tanks, emergency access, vegetation management zones
- Human impacts – vehicle movements, pets, mowing, tracks and access routes
- Sites where erosion and sediment runoff is evident and/or likely during works
- Water – route of stormwater flows, areas subject to flooding, nutrients and septic tank discharge
- Grazing/stock management issues – pasture management, animal waste, water supply, fencing of bushland and waterways/dams.

Establish Management Zones

- Living or domestic use zone
- Conservation zone
- Production (e.g. agricultural, grazing areas) zone, if appropriate.

Action/Implementation Plan

This is one of the most important parts of the Land Management Plan. Your action plan must prescribe specific actions and recommendations to address environmental issues. The actions and recommendations should follow the SMART principle.

S – specific: be clear and precise in what you are actually meaning to do. Avoid vague or generalised recommendations.

M – measurable: your actions must be measurable so that the impact or outcome of your action can be determined.

A – achievable: your actions must be practical and within reach, not beyond the scope of what you can realistically achieve.

R – reasonable: make sure what you are proposing to do is a reasonable and considered response to the issue at hand. Do not be too ambitious nor too lax in establishing goals and implementing actions.

T – timetabled: each action/recommendation must specify exactly when it will be done – i.e. when will it be commenced and when it will be finished. Specify the month and the year. Avoid use of terms such as ‘annually’, ‘as required’ or ‘seasonally’.

The Action Plan should also show priorities e.g. by describing priority areas or priority works. It should include a map and detail the proposed methods and timing for the works. You may find the Action Plan template below useful.

MONITORING AND IMPLEMENTATION

The life, or period of time for which a LMP is relevant, should be five years and include ongoing monitoring. Council’s Environmental Investigations Officer will check on and monitor the implementation and progress of your plan.

FURTHER ADVICE AND ASSISTANCE

Council’s Environmental Officers are available to assist with your plan and help achieve your goals. You may be eligible for financial incentives and subsidies to undertake the actions and recommendations of your plan. Council also encourages applicants to explore Conservation Covenants, Land for Wildlife and other programs that protect and enhance environmental values. Council offers a Property Management Planning Course for those that prepare their own plan and learn more about how to manage their property in an environmentally sustainable manner.

Contact Council’s Economic and Environmental Planning Unit on 9840 9124 for further information.

EXAMPLE ACTION PLAN:

| Action | Location | Control method | Herbicide/ Chemical Use | Timing | Priority |
|----------------------|---|---|--------------------------------|---|----------|
| Eradicate Blackberry | Along gully in south western corner of property | Spray by contractor. Hand pull small seedlings | Garlon as per label directions | Jan-Feb 2007 with follow-up in Jan-Feb 2008 | High |
| Control rabbits | All active warrens located and mapped | - Closure of warrens by manual digging | n/a | Prior to peak spring breeding period | High |
| | | - Baiting program as part of neighbourhood rabbit group | Pindone | Summer | High |
| | | - Fencing off or dismantling harbours | n/a | All year | High |
| | | - Continue to monitor for reinvasion | n/a | All year | High |

9. FURTHER INFORMATION RESOURCES AND CONTACTS

- The **Country Fire Authority (CFA)** provides a diverse range of risk reduction, fire suppression and incident management services to minimise the impact of fires and other emergencies on Victorian communities. The CFA provide information on making your home safe from house fires and bushfires. Visit www.cfa.vic.gov.au
- The **Department of Sustainability and Environment (DSE)** is Victoria's lead government agency for sustainable management of water resources, climate change, bushfires, public land, forests and ecosystems. Phone 13 61 86 or visit www.dse.vic.gov.au
- The **Department of Planning and Community Development (DPCD)** has a central role in managing Victoria's growth and development and building stronger communities. DPCD provides access to the Manningham Planning Scheme controls and maps and a range of general planning advice, including information on the Bushfire Management Overlay (BMO). Visit www.dpcd.vic.gov.au
- The **Department of Primary Industries (DPI)** has a good range of Landcare Notes that provide detail on many issues and topics relevant to rural or semi-rural property owners. Phone 13 61 86 or visit www.dpi.vic.gov.au
- The **Building Commission** is a statutory authority that oversees the building control system in Victoria. They oversee building legislation, regulate building practices, advise Government, and provide services to industry and consumers. Visit www.buildingcommission.com.au
- The **'Code of Practice - Private Tennis Court Development – Revision 1, March 1999'** is available for download from the Department of Planning and Community Development website. Visit www.dpcd.vic.gov.au/planning/publicationsandresearch/codes-and-guidelines
- The **'What you need to know about 6-Star'** information sheet and frequently asked questions on the new building energy efficiency standard are available for download from the Victorian Building Commission website. Visit www.buildingcommission.com.au/www/html/2562-introduction-of-6-star.asp
- The **'Native Splendour – A gardening guide to Manningham's local plants'** gardening booklet on Manningham's indigenous plants designed to help you use plants that will enhance your garden and are perfectly suited to local climate and soils. The booklet also includes tips for planning and planting your garden and is available from Council's Economic and Environmental Planning Unit. Phone 9840 9124 or visit www.manningham.vic.gov.au/environment



A group of 'Property Management Planning Course' participants learning about sustainable land management principles

- **'Weeds – Identification and control of common weeds in Manningham'** is an illustrated and informative booklet that clearly identifies Manningham's worst weeds and provides information on how to best control them. The booklet is available from Council's Economic and Environmental Planning Unit. Phone 9840 9124 or visit www.manningham.vic.gov.au/environment
- The **'Land Management Guide'** booklet aims to help small property owners improve management of their land to the benefit of the local environment. The booklet is available from Council's Economic and Environmental Planning Unit. Phone 9840 9124 or visit www.manningham.vic.gov.au/environment
- The **'Home Harvest Booklet'** has everything you need to know about growing your own food. The booklet is available from Council's Economic and Environmental Planning Unit. Phone 9840 9124 or visit www.manningham.vic.gov.au/environment
- The **Living Greener** website provides a starting point for information about living more sustainably and reducing your environmental impact. It includes information on programs and financial support available from the Australian Government as well as state and territory governments. Visit www.livinggreener.gov.au
- **Manningham City Council**, 699 Doncaster Road (P.O. Box 1), Doncaster 3108. Phone 9840 9333 or visit www.manningham.vic.gov.au

Contacting Council

Manningham Civic Centre

699 Doncaster Road, Doncaster
Melway ref. 33 E12

Council Depot

corner Blackburn Road and Warrandyte Road,
Doncaster East
Melway ref. 34 D3

General Information

phone 03 9840 9333
fax 03 9848 3110
email manningham@manningham.vic.gov.au
www.manningham.vic.gov.au
twitter.com/manninghamcc

For emergencies and to contact Council outside
normal business hours please call 9840 9333.

Translation details

An interpreting service is available if
required by contacting Manningham
City Council on 9840 9333.

Arabic / عربي

خدمة الترجمة متاحة إذا لزم الأمر عن طريق الاتصال بمجلس
بلدية مدينة مانينجهام على هاتف رقم 9840 9333.

Chinese / 中文

需要的话可以提供翻译服务，联系
Manningham市政厅电话9840 9333。

Greek / Ελληνικά

Υπηρεσία διερμηνείας είναι διαθέσιμη,
αν απαιτείται, επικοινωνώντας με το
Δημοτικό Συμβούλιο του Manningham
στο 9840 9333.

Italian / Italiano

È possibile utilizzare il servizio
d'interpretariato se necessario
telefonando al comune di Manningham,
al 9840 9333.

Korean / 한국어

통역 서비스를 원하시면 매닝햄
시의회에 9840 9333으로 연락하셔서
요청하시면 됩니다.

Macedonian / Македонски

Ако ви треба преведувачка услуга јавете
се на Општина Манингам на 9840 9333.

Persian / فارسی

خدمات ترجمه شفاهی موجود است. در صورت نیاز می
توانید با شهرداری منینگهام به شماره تلفن 9840 9333
تماس بگیرید.